

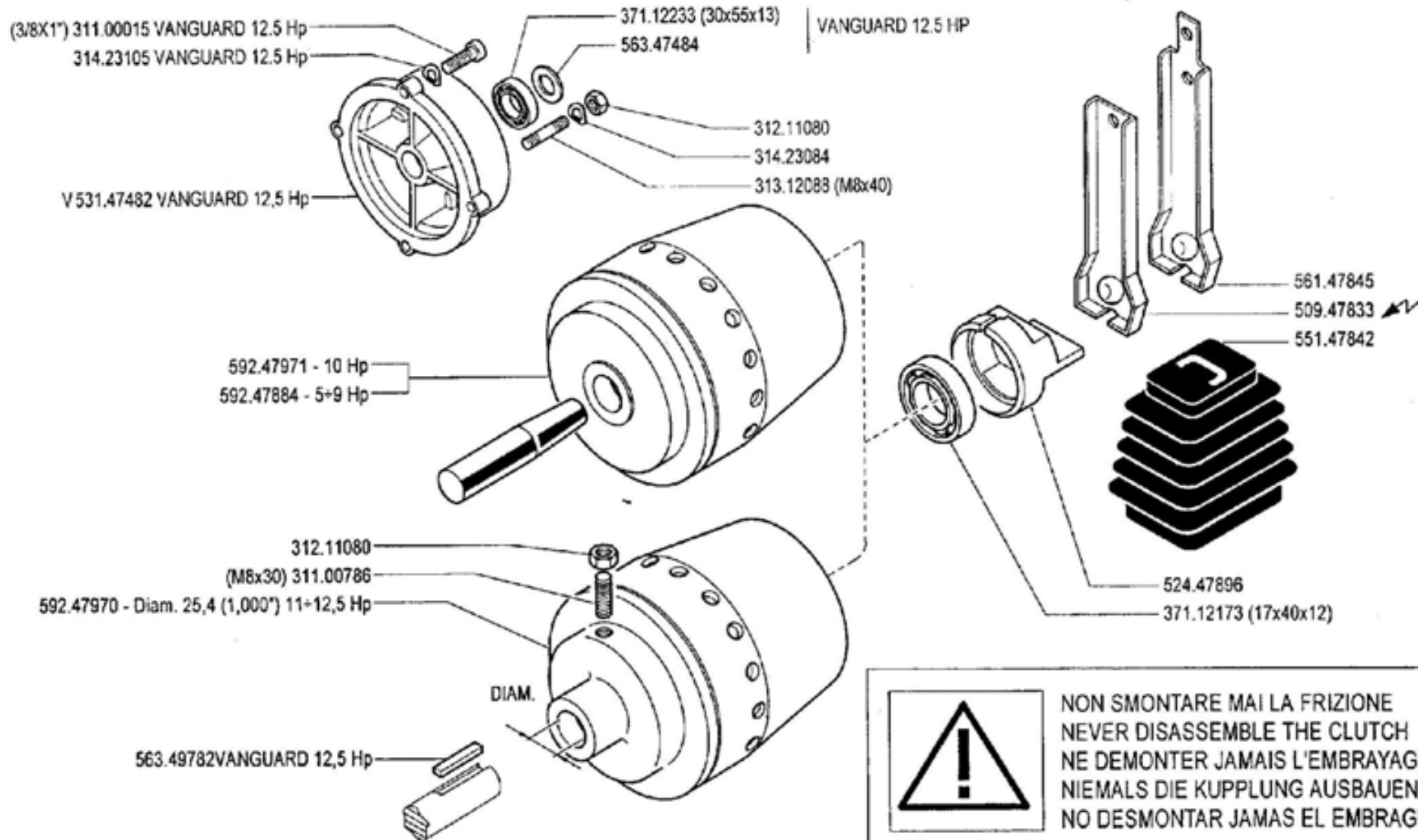

Inhoudsopgave

Drijfwerk Huis '02	13
Index	53
Koppeling '02	9
PTO & Tandielen	15
Schakelpoken	35
Stickers '03	49
Stuur & Kabels '02	31
Stuurboom	25
Wielas & Flenzen	23
Wielen	39

Code	Description	Notes
002_0_12722	SELF-VENTILATING CONE CLUTCH	
002_1_12741	SELF-VENTILATING CONE CLUTCH	
002_2_12761	SELF-VENTILATING CONE CLUTCH	
002_3_12779	SELF-VENTILATING CONE CLUTCH	
03A_1_13913	GEARBOX (510-515-515L-515S)	
03A_2_13945	GEARBOX (510-515-515L-515S)	
04B_0_14068	GEARS (515L-515S)	
04B_1_14105	GEARS (515L-515S)	
005_2_13039	WHEEL AXLE	
07A_0_14343	STEERING COLUMN (515-515L-515S)	
08A_0_14359	HANDLEBAR (515-515L-515S)	
08A_1_14405	HANDLEBAR (515-515L-515S)	
09A_0_14579	CONTROLS (515-515L-515S)	
011_3_13744	WHEELS	
012_0_13785	STICKERS	
012_1_13807	STICKERS	
012_2_13824	STICKERS	
013_1_13860	STICKERS	
013_0_13845	STICKERS	



V = verde - vert - green - grün

 NON SMONTARE MAI LA FRIZIONE
 NEVER DISASSEMBLE THE CLUTCH
 NE DEMONTER JAMAIS L'EMBRAYAGE
 NIEMALS DIE KUPPLUNG AUSBAUEN
 NO DESMONTAR JAMAS EL EMBRAGUE

FERRARI	500 serie 95	FRIZIONE A CONO AUTOVENTILANTE		DALLA MACCHINA	02.00
		EMBRAGUE	CLUTCH	DE LA MAQUINA	
		EMBRAYAGE	KUPPLUNG	DE LA MACHINE	01.06.1995
				FROM THE MACHINE	
				AB DER MASCHINE	
				N.	

Pos.	Code	Q.ty	Description	Notes
31100015	31100015	0	SCREW TE 3/8X1	
31100786	31100786	0	SCREW STEI M8X30 UNI5923 8G	
31211080	31211080	0	NUT M8	
31312088	31312088	0	STUD BOLT M8X40X14X14	
31423084	31423084	0	SPRING WASHER 8,4	
31423105	31423105	0	SPRING WASHER 10,5	
37112173	37112173	0	BEARING	
37112233	37112233	0	BEARING	
50947833	50947833	0	CLUTCH LEVER	
52447896	52447896	0	PRESSURE PLATE	
53147482	53147482	0	ENGINE FLANGE	
55147842	55147842	0	BELLOWS	
56147845	56147845	0	CLUTCH LEVER	
56347484	56347484	0	SHIM	
56349782	56349782	0	DOWEL	
59247884	59247884	0	CLUTCH ASSY	
59247970	59247970	0	CLUTCH	
59247971	59247971	0	CLUTCH	

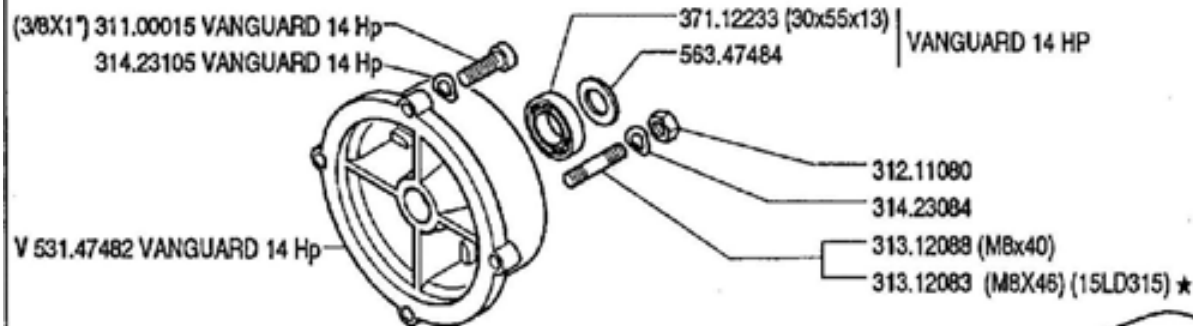

MOTORE ENGINE MOTEUR MOTOR MOTOR	A	FRIZIONE EMBRAGUE EMBRAYAGE KUPPLUNG CLUTCH
Acme A220		592.47884
Acme ALN 330W		592.47884
Acme AT 330W		592.47971
Intermotor IM 359		592.47884
Briggs & Stratton Vanguard 14 Hp		592.47970
Lombardini 15 LD 315		592.47884
Lombardini 6 LD 435/400		592.47971

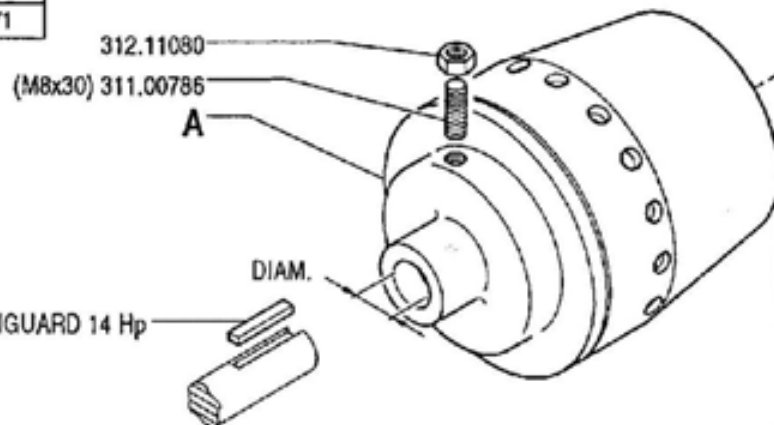
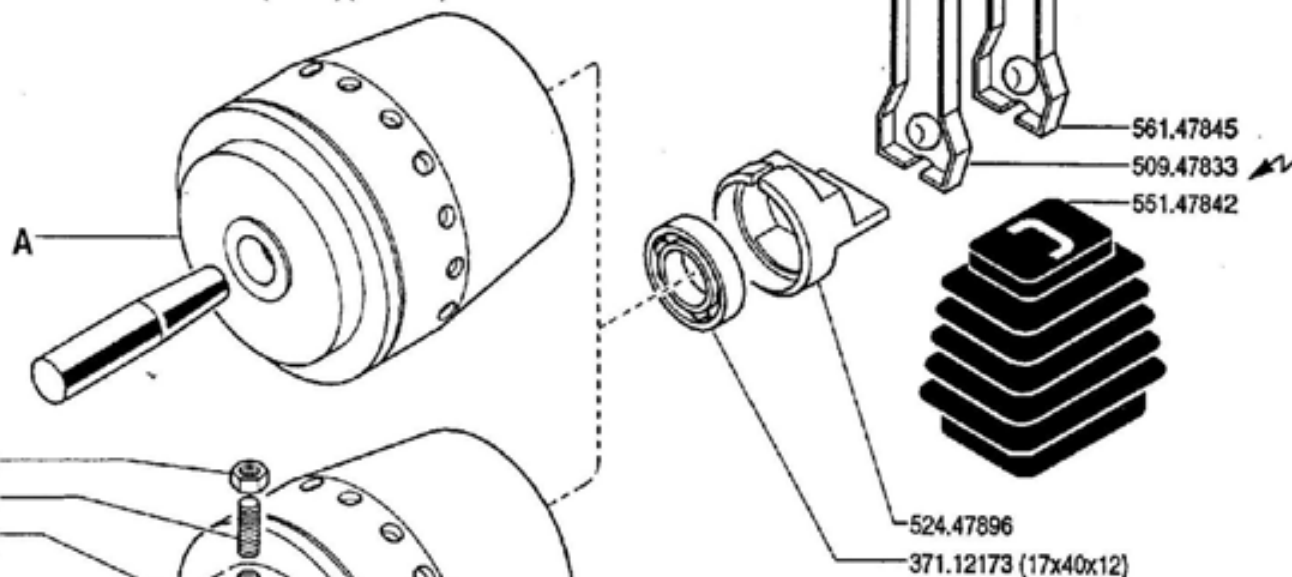

V = verde - vert - green - grün

NON SMONTARE MAI LA FRIZIONE
NEVER DISASSEMBLE THE CLUTCH
NE DEMONTER JAMAIS L'EMBRAYAGE
NIEMALS DIE KUPPLUNG AUSBAUEN
NO DESMONTAR JAMAS EL EMBRAGUE

FERRARI	500 serie 95	FRIZIONE A CONO AUTOVENTILANTE		DALLA MACCHINA DE LA MAQUINA DE LA MACHINE FROM THE MACHINE AB DER MASCHINE	AGGIORNAMENTO	02.01
		EMBRAGUE	CLUTCH		REVISION	
		EMBRAYAGE	KUPPLUNG	★ N.	MISE A JOUR	
					APLAZAMIENTO	02.09.1996
					ANPASSUNG	

Pos.	Code	Q.ty	Description	Notes
31100015	31100015	0	SCREW TE 3/8X1	
31100786	31100786	0	SCREW STEI M8X30 UNI5923 8G	
31211080	31211080	0	NUT M8	
31312083	31312083	0	STUD BOLT M8X46X16X16	
31312088	31312088	0	STUD BOLT M8X40X14X14	
31423084	31423084	0	SPRING WASHER 8,4	
31423105	31423105	0	SPRING WASHER 10,5	
37112173	37112173	0	BEARING	
37112233	37112233	0	BEARING	
50947833	50947833	0	CLUTCH LEVER	
52447896	52447896	0	PRESSURE PLATE	
53147482	53147482	0	ENGINE FLANGE	
55147842	55147842	0	BELLOWS	
56147845	56147845	0	CLUTCH LEVER	
56347484	56347484	0	SHIM	
56349782	56349782	0	DOWEL	
59247884	59247884	0	CLUTCH ASSY	
59247970	59247970	0	CLUTCH	
59247971	59247971	0	CLUTCH	

★ (HONDA G150 - Gx160 - Gx200) 311.00003

371.12231 (HONDA G150 - Gx160 - Gx200) ★

563.56251 (HONDA G150 - Gx160 - Gx200) ★

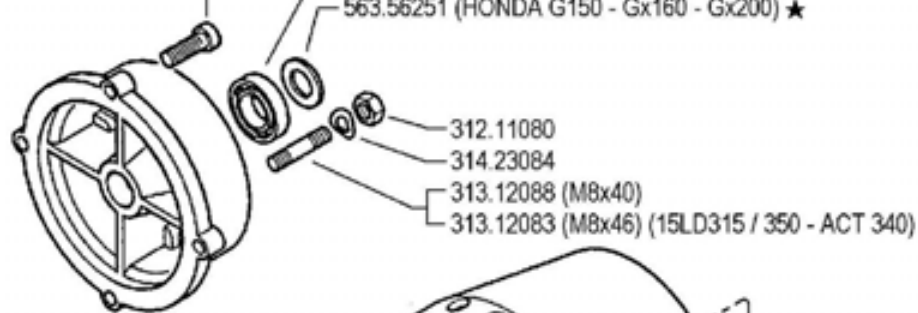

★ (HONDA G150 - Gx160 - Gx200) V 532.47468

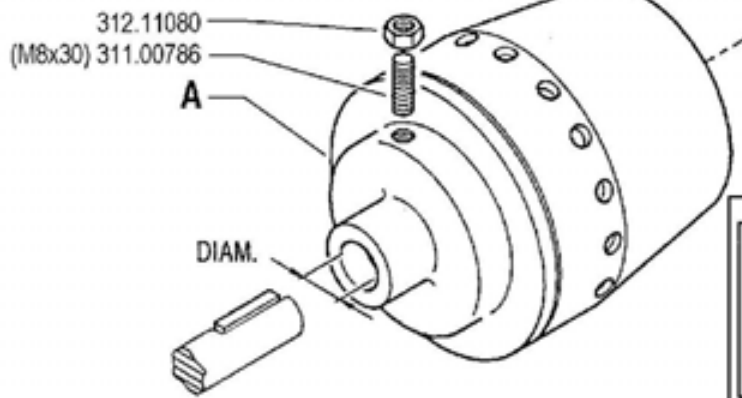
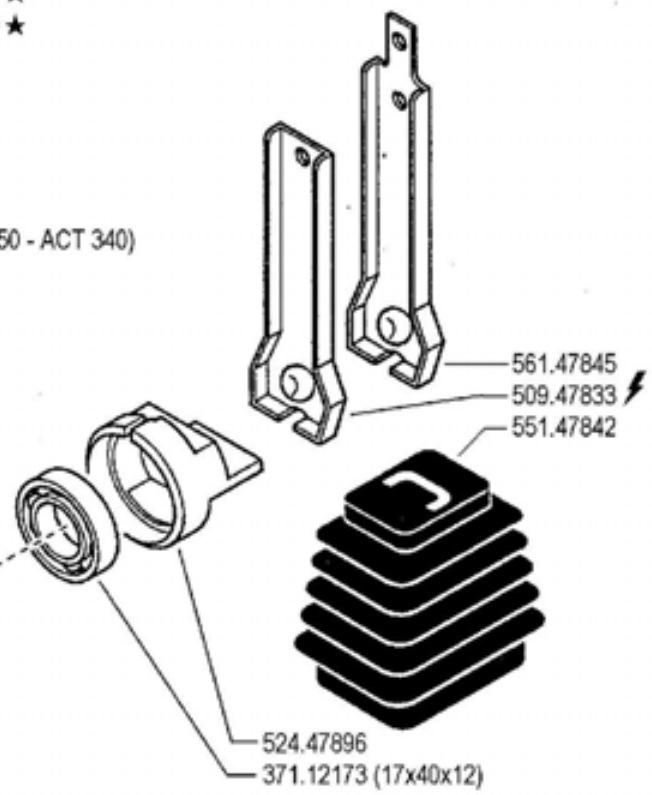
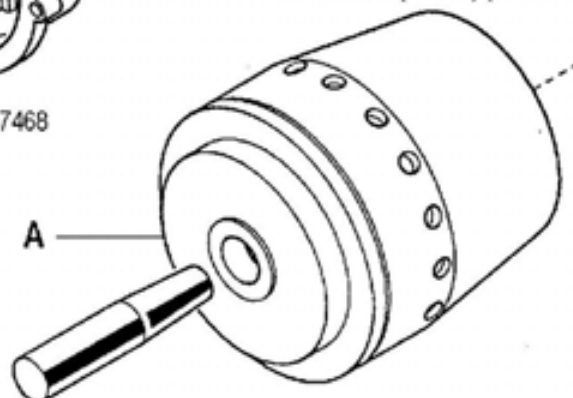

MOTORE ENGINE MOTEUR MOTOR	A	FRIZIONE EMBRAGUE KUPPLUNG CLUTCH
Acme A 220		592.47884
Acme ALN 330W - ACT 280 ★		592.47884
Acme AT 330W - ACT 340 ★		592.47971
Honda G150 - Gx160 - Gx200 ★		592.56252
Intermotor IM 359		592.47884
Lombardini 15 LD 315 / 350		592.47884
Yanmar L100 AE ★		592.47971

**NON SMONTARE MAI LA FRIZIONE
NEVER DISASSEMBLE THE CLUTCH
NE DEMONTER JAMAIS L'EMBRAYAGE
NIEMALS DIE KUPPLUNG AUSBAUEN
NO DESMONTAR JAMAS EL EMBRAGUE**

V = verde - green - vert - grün

FERRARI

500 serie 95

FRIZIONE A CONO AUTOVENTILANTE

CLUTCH
EMBRAGUE

EMBRAYAGE
KUPPLUNG

DALLA MACCHINA
DE LA MAGINA
DE LA MACHINE
FROM THE MACHINE
AB DER MASCHINE

AGGIORNAMENTO

REVISION

MISE A JOUR

APLAZAMIENTO

ANPASSUNG

02

Vol. 02

1/2000

★N.

ZB/MS

Pos.	Code	Q.ty	Description	Notes
31100003	31100003	0	SCREW TE 5/16X7/8	
31100786	31100786	0	SCREW STEI M8X30 UNI5923 8G	
31211080	31211080	0	NUT M8	
31312083	31312083	0	STUD BOLT M8X46X16X16	
31312088	31312088	0	STUD BOLT M8X40X14X14	
31423084	31423084	0	SPRING WASHER 8,4	
37112173	37112173	0	BEARING	
37112231	37112231	0	BEARING	
50947833	50947833	0	CLUTCH LEVER	
52447896	52447896	0	PRESSURE PLATE	
53247468	53247468	0	FLANGE	
55147842	55147842	0	BELLOWS	
56147845	56147845	0	CLUTCH LEVER	
56356251	56356251	0	SHIM D=19,6	
59247884	59247884	0	CLUTCH ASSY	
59247971	59247971	0	CLUTCH	
59256252	59256252	0	CLUTCH ASSY	

HONDA G150 - Gx 120/160/200 311.00003
 HONDA Gx 340 ★ 311.00015

HONDA Gx 340 ★ 314.23105

371.12231 HONDA G150 - Gx 120/160/200
 371.12233 (30x55x13) - HONDA Gx 340 ★

563.47484 - HONDA Gx 340 ★
 563.56251 HONDA G150 - Gx 120/160/200

312.11080

314.23084

313.12088 (M8x40)

313.12083 (M8x46) (15LD315/350 - ACT 280/340 - L100AE)

HONDA G150 - Gx 120/160/200 (2) ★ 532.47488
 HONDA Gx 340 ★ 531.56150

MOTORE ENGINE MOTEUR MOTOR	A FRIZIONE EMBRAYAGE KUPPLUNG CLUTCH
Acme A220	592.47884
Acme ACT 280 - A349 ★ - A360 ★	592.47884
Acme ACT 340	592.47871
Honda Gx 340 ★	592.56257
Honda G150 - Gx 120 / 160 / 200	592.56265 ★ (1)
Intermotor IM 359	592.47884
Lombardini 15LD315 / 350	592.47884
Yanmar L100AE	592.47971

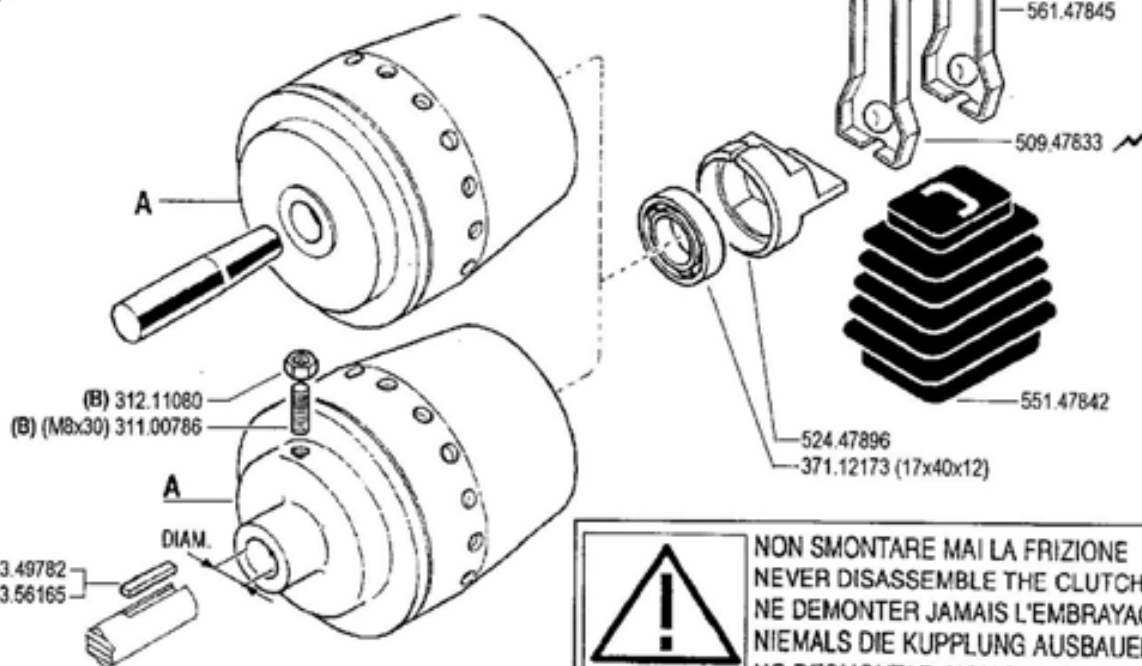

(HONDA Gx 340 ★) 563.49782
 (HONDA G150 - Gx120/160/200) ★ 563.56165

(2) sostituisce V532.47468
 (1) sostituisce 592.56252

 NON SMONTARE MAI LA FRIZIONE
 NEVER DISASSEMBLE THE CLUTCH
 NE DEMONTER JAMAIS L'EMBRAYAGE
 NIEMALS DIE KUPPLUNG AUSBAUEN
 NO DESMONTAR JAMAS EL EMBRAGUE

(B) serrare a 2 kgm

FERRARI

500 serie 95

FRIZIONE A CONO AUTOVENTILANTE

CLUTCH
 EMBRAGUE

EMBRAYAGE
 KUPPLUNG

DALLA MACCHINA
 DE LA MAQUINA
 DE LA MACHINE
 FROM THE MACHINE
 AB DER MASCHINE

(1) 4194 (515)
 (1) 166207 (520)

02

Rev.
 3

12/2002

303NE

★N.

Pos.	Code	Q.ty	Description	Notes
31100003	31100003	0	SCREW TE 5/16X7/8	
31100015	31100015	0	SCREW TE 3/8X1	
31100786	31100786	0	SCREW STEI M8X30 UNI5923 8G	
31211080	31211080	0	NUT M8	
31312083	31312083	0	STUD BOLT M8X46X16X16	
31312088	31312088	0	STUD BOLT M8X40X14X14	
31423084	31423084	0	SPRING WASHER 8,4	
31423105	31423105	0	SPRING WASHER 10,5	
37112173	37112173	0	BEARING	
37112231	37112231	0	BEARING	
37112233	37112233	0	BEARING	
50947833	50947833	0	CLUTCH LEVER	
52447896	52447896	0	PRESSURE PLATE	
53156150	53156150	0	ENGINE FLANGE	
53247488	53247488	0	ENGINE FLANGE	
55147842	55147842	0	BELLOWS	
56147845	56147845	0	CLUTCH LEVER	
56347484	56347484	0	SHIM	
56349782	56349782	0	DOWEL	
56356165	56356165	0	DOWEL	
56356251	56356251	0	SHIM D=19,6	
59247884	59247884	0	CLUTCH ASSY	
59247971	59247971	0	CLUTCH	
59256257	59256257	0	CLUTCH ASSY	
59256265	59256265	0	CLUTCH ASSY	

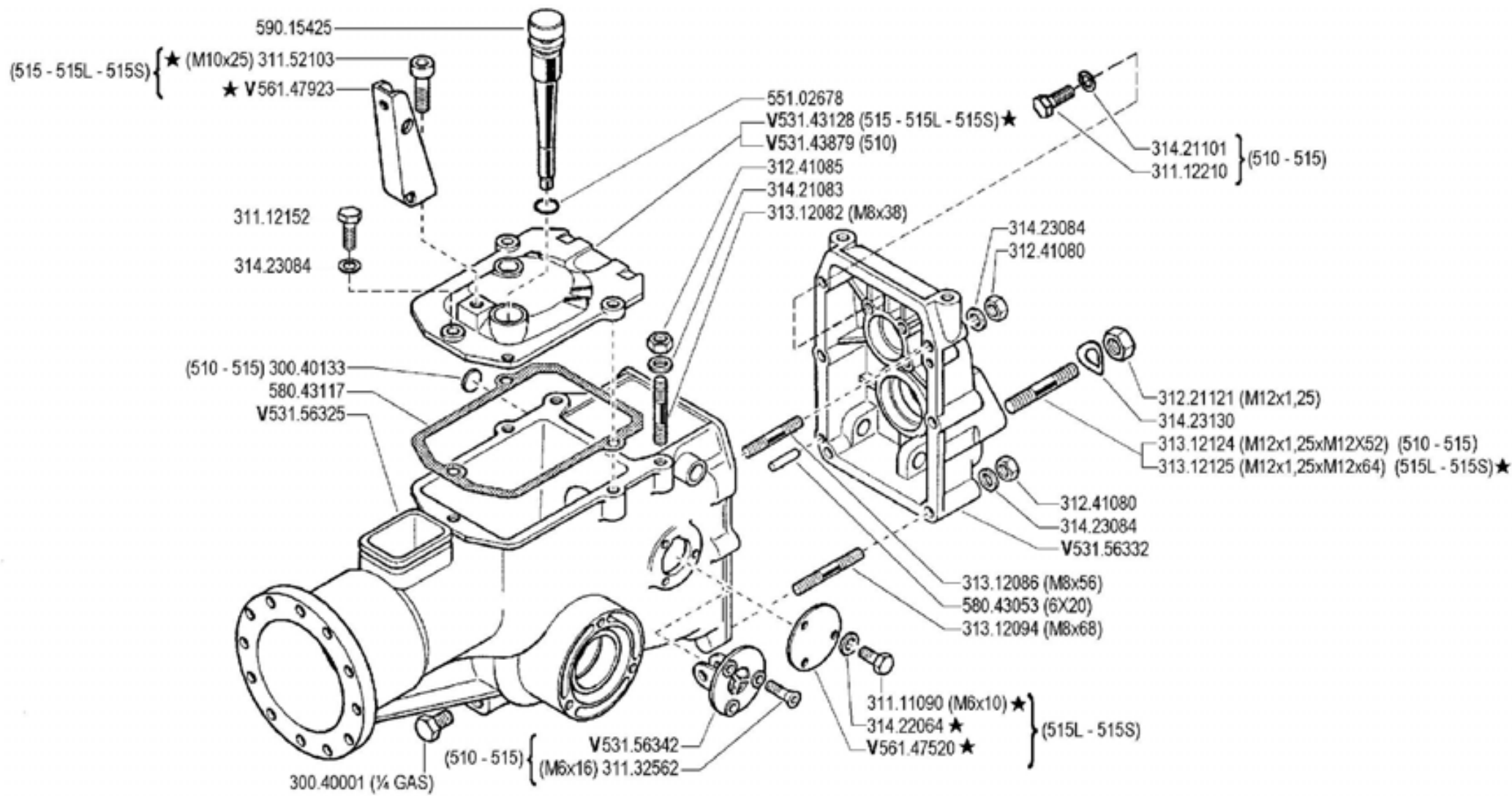

V = verde - green - vert - grün

FERRARI	500 serie 95	SCATOLA CAMBIO (510 - 515 - 515L - 515S)		DALLA MACCHINA DE LA MAGINA DE LA MACHINE FROM THE MACHINE AB DER MASCHINE	AGGIORNAMENTO	03 A 01	No.
		GEARBOX	BOITE DE VITESSES		REVISION		1/2000
		CAJA DE CAMBIO	WECHSELGETRIEBE		MISE A JOUR		
					APLAZAMENTO		
					ANPASSUNG		

★N.

ZB/MS

Pos.	Code	Q.ty	Description	Notes
30040001	30040001	0	PLUG	
30040133	30040133	0	PLUG 22 DIN 470	
31111090	31111090	0	SCREW TE M5X10 UNI 5739 8G	
31112152	31112152	0	SCREW TE M8X30 UNI 5739 8G	
31112210	31112210	0	SCREW TE M10X20 UNI 5739	
31132562	31132562	0	SCREW TSVEI M6X16 UNI 5933	
31152103	31152103	0	SCREW TCEI M10X25 UNI 5931	
31221121	31221121	0	NUT M12X1,25	
31241080	31241080	0	SELFLOCK NUT M8	
31241085	31241085	0	SELFLOCK NUT M8 6S	
31312082	31312082	0	STUD BOLT M8X38X14X20	
31312086	31312086	0	STUD BOLT M8X56X20X14	
31312094	31312094	0	STUD BOLT M8X68X14X36	
31312124	31312124	0	STUD BOLT	
31312125	31312125	0	STUD BOLT	
31421083	31421083	0	WASHER	
31421101	31421101	0	WASHER	
31422064	31422064	0	SPRING WASHER 6,4	
31423084	31423084	0	SPRING WASHER 8,4	
31423130	31423130	0	SPRING WASHER 13	
53143128	53143128	0	COVER	
53143879	53143879	0	GEARBOX HOUSING COVER	
53156325	53156325	0	BODY	
53156332	53156332	0	REAR COVER	
53156342	53156342	0	GEAR SUPPORT	
55102678	55102678	0	RUBBER RING	
56147520	56147520	0	COVER	
56147923	56147923	0	BRACKET	
58043053	58043053	0	CYLINDRICAL PLUG	
58043117	58043117	0	COVER GASKET	
59015425	59015425	0	PLUG	

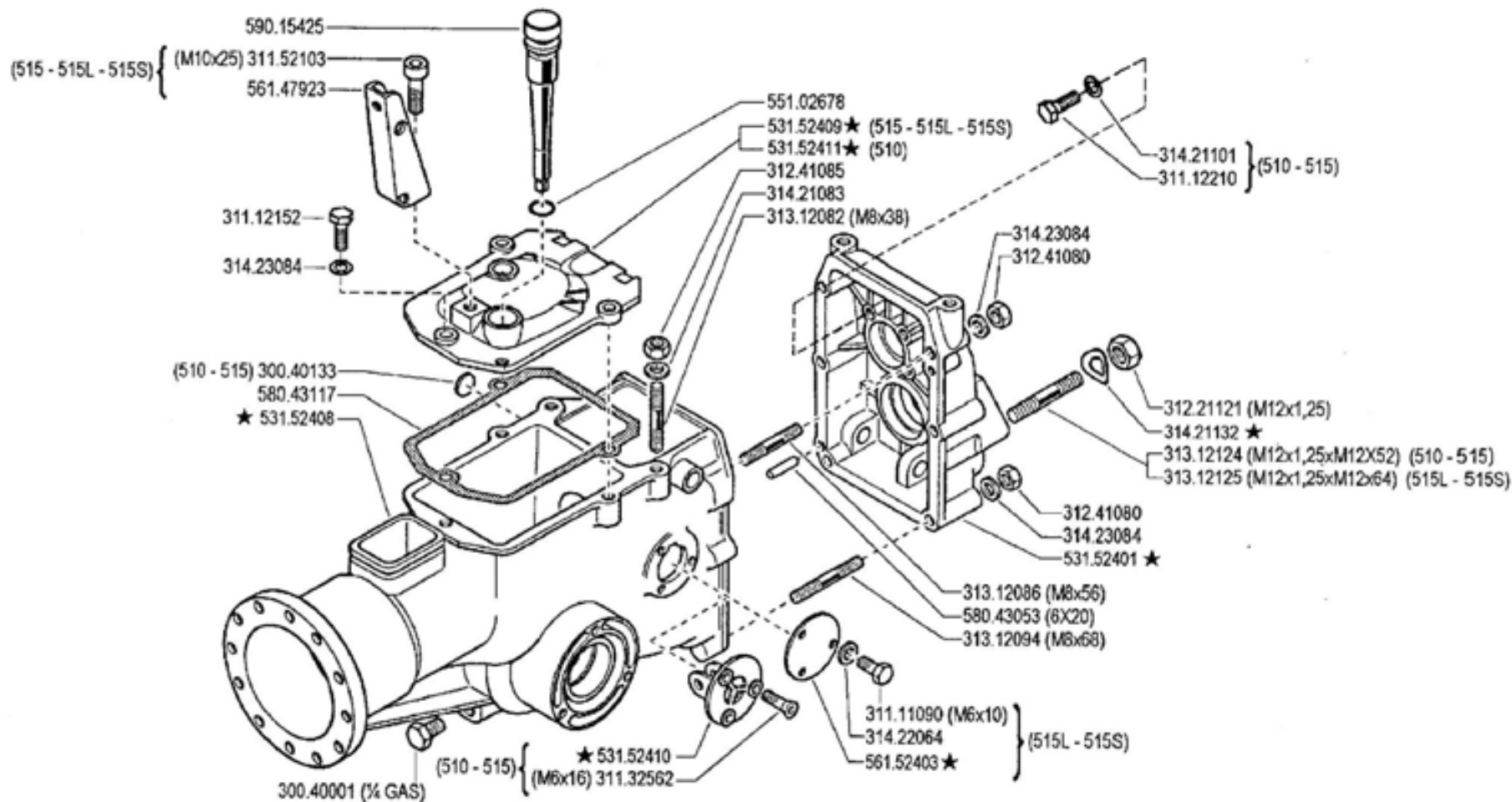

FERRARI

500 serie 95

SCATOLA CAMBIO (510 - 515 - 515L - 515S)

GEARBOX
CAJA DE CAMBIO

BOITE DE VITESSES
WECHSELGETRIEBE

DALLA MACCHINA
DE LA MAQUINA
DE LA MACHINE
FROM THE MACHINE
AB DER MASCHINE

AGGIORNAMENTO
REVISION
MISE A JOUR
APLAZAMIENTO
ANPASSUNG

03 A 2

12/2002

★N

27000

Pos.	Code	Q.ty	Description	Notes
30040001	30040001	0	PLUG	
30040133	30040133	0	PLUG 22 DIN 470	
31111090	31111090	0	SCREW TE M5X10 UNI 5739 8G	
31112152	31112152	0	SCREW TE M8X30 UNI 5739 8G	
31112210	31112210	0	SCREW TE M10X20 UNI 5739	
31132562	31132562	0	SCREW TSVEI M6X16 UNI 5933	
31152103	31152103	0	SCREW TCEI M10X25 UNI 5931	
31221121	31221121	0	NUT M12X1,25	
31241080	31241080	0	SELFLOCK NUT M8	
31241085	31241085	0	SELFLOCK NUT M8 6S	
31312082	31312082	0	STUD BOLT M8X38X14X20	
31312086	31312086	0	STUD BOLT M8X56X20X14	
31312094	31312094	0	STUD BOLT M8X68X14X36	
31312124	31312124	0	STUD BOLT	
31312125	31312125	0	STUD BOLT	
31421083	31421083	0	WASHER	
31421101	31421101	0	WASHER	
31421132	31421132	0	WASHER 13X24X2,8	
31422064	31422064	0	SPRING WASHER 6,4	
31423084	31423084	0	SPRING WASHER 8,4	
53152401	53152401	0	REAR COVER	
53152408	53152408	0	BODY	
53152409	53152409	0	COVER	
53152410	53152410	0	GEAR SUPPORT	
53152411	53152411	0	GEARBOX HOUSING COVER	
55102678	55102678	0	RUBBER RING	
56147923	56147923	0	BRACKET	
56152403	56152403	0	COVER	
58043053	58043053	0	CYLINDRICAL PLUG	
58043117	58043117	0	COVER GASKET	
59015425	59015425	0	PLUG	

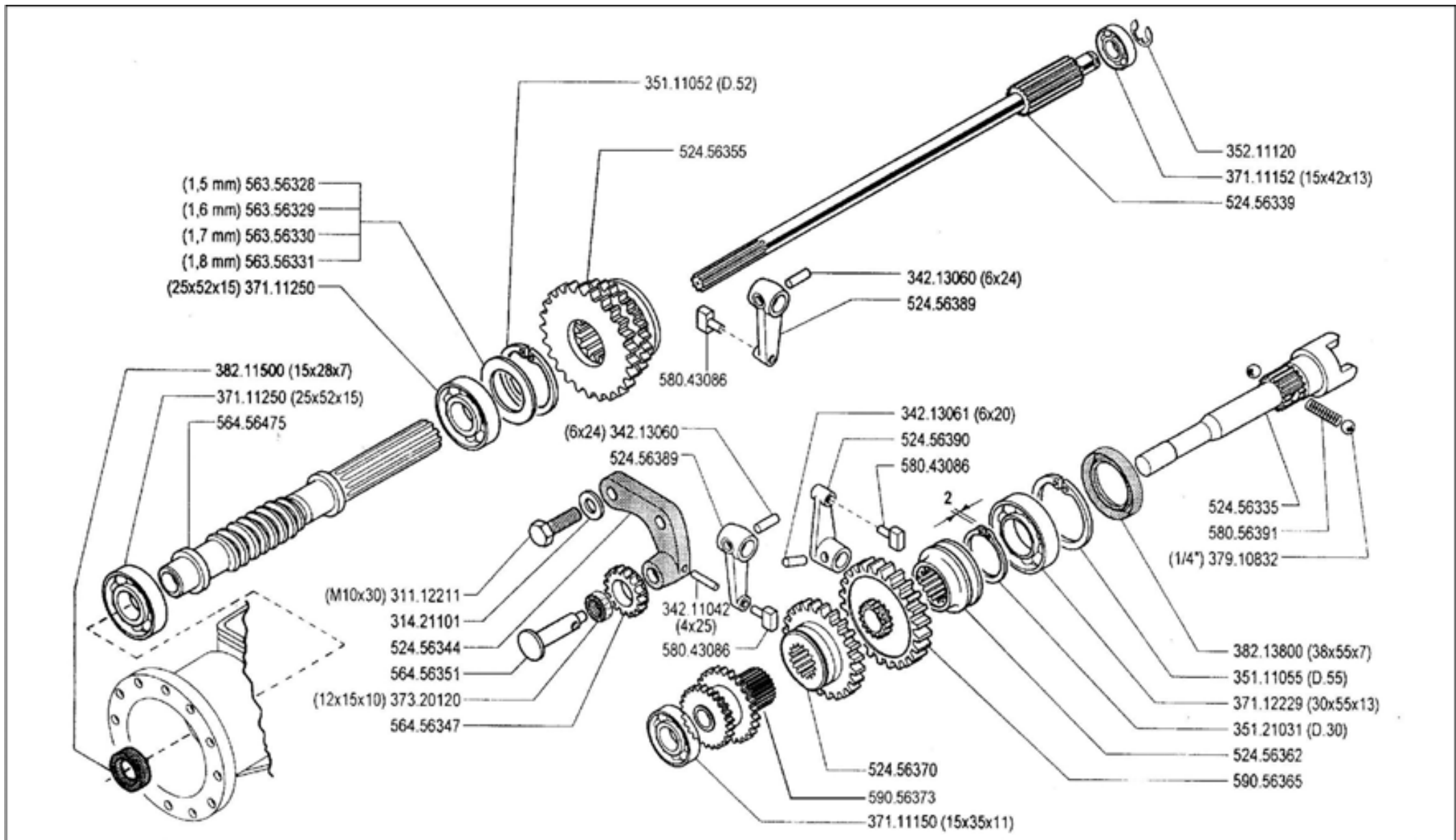

	500 serie 95	INGRANAGGI CAMBIO (515L - 515S)		DALLA MACCHINA DE LA MAQUINA DE LA MACHINE FROM THE MACHINE AB DER MASCHINE	Vid 04 B 00
		GEARS ENGRANAJES	ENGRANAGES ZÄHNRÄDER		

Pos.	Code	Q.ty	Description	Notes
31112211	31112211	0	SCREW TE M10X30 UNI 5739	
31421101	31421101	0	WASHER	
34211042	34211042	0	ROLL PIN	
34213060	34213060	0	ROLL PIN	
34213061	34213061	0	ROLL PIN	
35111052	35111052	0	SEEGER RING I 52 DIN 472	
35111055	35111055	0	SEEGER RING I 55 DIN 472	
35121031	35121031	0	SEEGER RING E 30 UNI 7436	
35211120	35211120	0	SEEGER RING E 12 UNI 7434	
37111150	37111150	0	BEARING	
37111152	37111152	0	BEARING	
37111250	37111250	0	BEARING	
37112229	37112229	0	BEARING	
37320120	37320120	0	ROLLER CAGE 12X15/10	
37910832	37910832	0	BALL 1/4	
38211500	38211500	0	OIL SEAL 15X28X7	
38213800	38213800	0	OIL SEAL 38X55X7	
52456335	52456335	0	PTO SHAFT	
52456339	52456339	0	SHAFT	
52456344	52456344	0	GEAR SUPPORT	
52456355	52456355	0	SLIDER	
52456362	52456362	0	COUPLING	
52456370	52456370	0	SLIDER	
52456389	52456389	0	LEVER	
52456390	52456390	0	LEVER	
56356328	56356328	0	ADJUSTING RING SP=1,5	
56356329	56356329	0	ADJUSTING RING SP=1,6	
56356330	56356330	0	ADJUSTING RING SP=1,7	
56356331	56356331	0	ADJUSTING RING SP=1,8	
56456347	56456347	0	GEAR	
56456351	56456351	0	GEAR PIN	
56456475	56456475	0	SCREW	
58043086	58043086	0	SHOE	
58056391	58056391	0	SPRING	

SERIAL

GEARS (515L-515S)

CODE REV

04B_0_14068

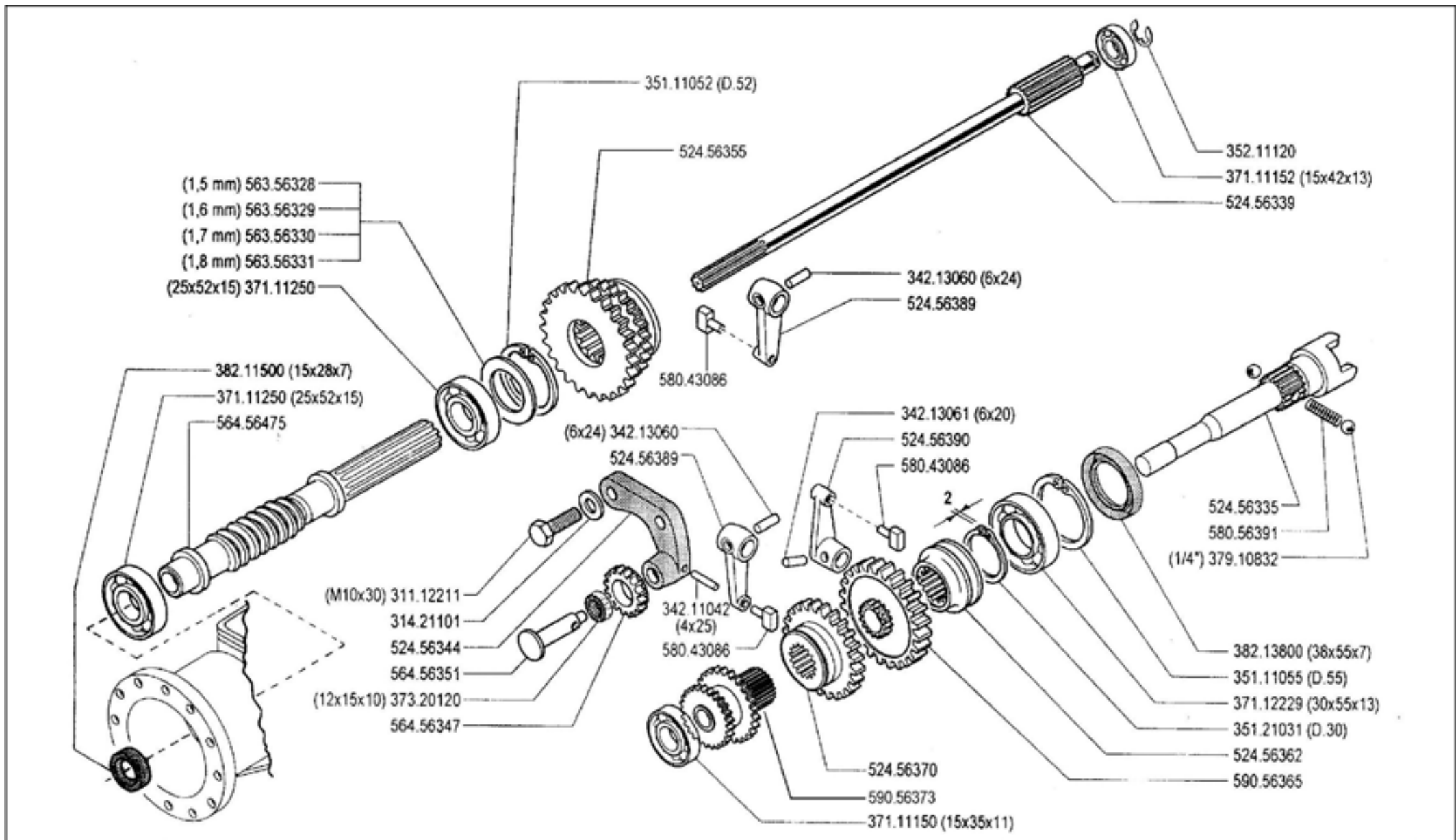

FERRARI

500 serie **95**

INGRANAGGI CAMBIO (515L - 515S)

GEARS
ENGRANAJES

ENGRANAGES
ZÄHRÄDER

DALLA MACCHINA
DE LA MAQUINA
DE LA MACHINE
FROM THE MACHINE
AB DER MASCHINE

N.

04 B 00

1/2000

Vid

FIN

Pos.	Code	Q.ty	Description	Notes
59056365	59056365	0	PTO GEAR	
59056373	59056373	0	DOUBLE GEAR	

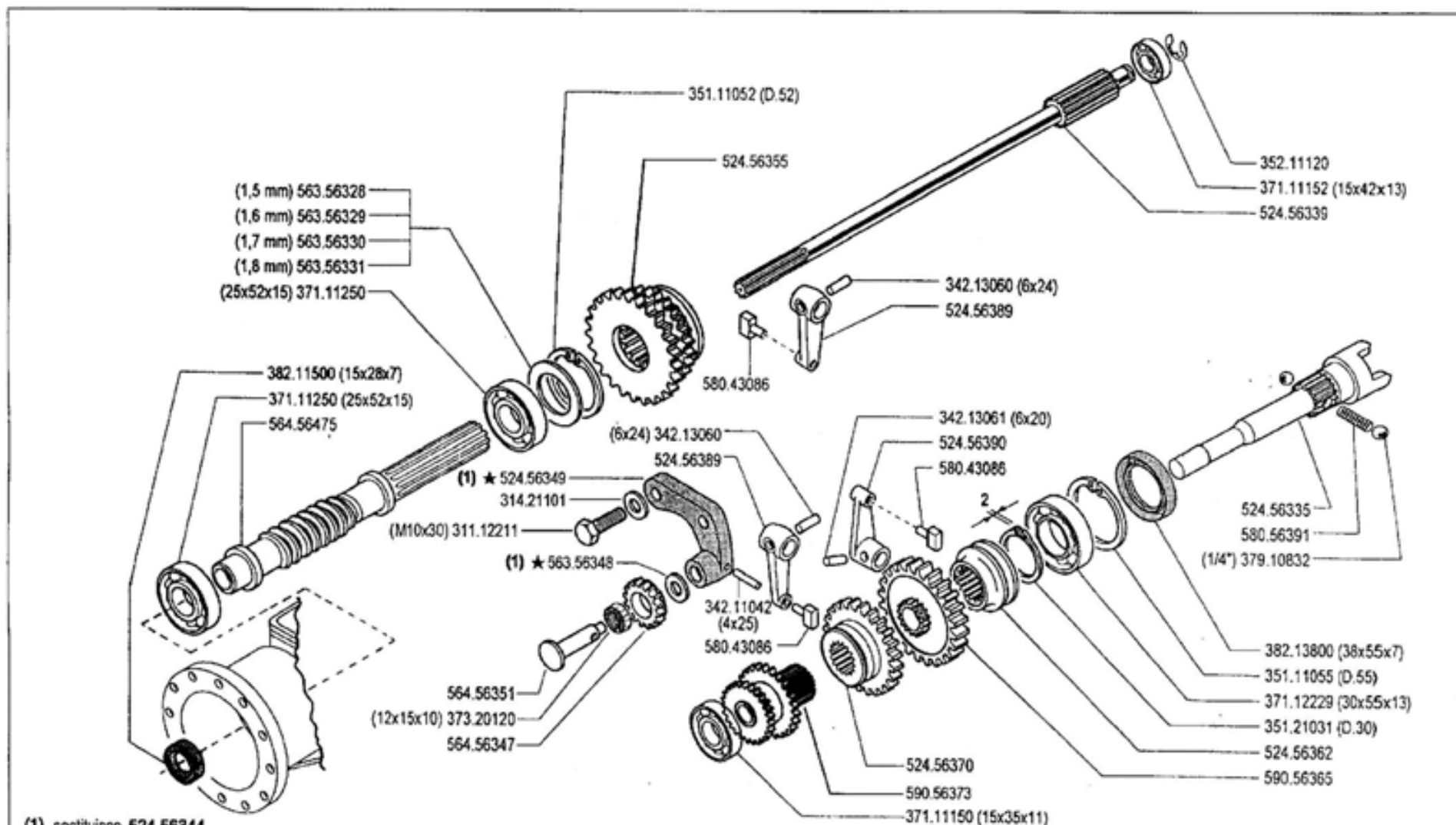

(1) sostituisce 524.56344

FERRARI

500 serie 95

INGRANAGGI CAMBIO (515L - 515S)

GEARS
ENGRANAJES

ENGRANAGES
ZÄHRÄDER

DALLA MACCHINA
DE LA MAQUINA
DE LA MACHINE
FROM THE MACHINE
AB DER MASCHINE

★N

AGGIORNAMENTO
REVISION
MISE A JOUR
APLAZAMIENTO
ANPASSUNG

04 B 1

9/2000

Rev.

1

FIN

Pos.	Code	Q.ty	Description	Notes
31112211	31112211	0	SCREW TE M10X30 UNI 5739	
31421101	31421101	0	WASHER	
34211042	34211042	0	ROLL PIN	
34213060	34213060	0	ROLL PIN	
34213061	34213061	0	ROLL PIN	
35111052	35111052	0	SEEGER RING I 52 DIN 472	
35111055	35111055	0	SEEGER RING I 55 DIN 472	
35121031	35121031	0	SEEGER RING E 30 UNI 7436	
35211120	35211120	0	SEEGER RING E 12 UNI 7434	
37111150	37111150	0	BEARING	
37111152	37111152	0	BEARING	
37111250	37111250	0	BEARING	
37112229	37112229	0	BEARING	
37320120	37320120	0	ROLLER CAGE 12X15/10	
37910832	37910832	0	BALL 1/4	
38211500	38211500	0	OIL SEAL 15X28X7	
38213800	38213800	0	OIL SEAL 38X55X7	
52456335	52456335	0	PTO SHAFT	
52456339	52456339	0	SHAFT	
52456349	52456349	0	GEAR SUPPORT	
52456355	52456355	0	SLIDER	
52456362	52456362	0	COUPLING	
52456370	52456370	0	SLIDER	
52456389	52456389	0	LEVER	
52456390	52456390	0	LEVER	
56356328	56356328	0	ADJUSTING RING SP=1,5	
56356329	56356329	0	ADJUSTING RING SP=1,6	
56356330	56356330	0	ADJUSTING RING SP=1,7	
56356331	56356331	0	ADJUSTING RING SP=1,8	
56356348	56356348	0	ADJUSTING RING	
56456347	56456347	0	GEAR	
56456351	56456351	0	GEAR PIN	
56456475	56456475	0	SCREW	
58043086	58043086	0	SHOE	

SERIAL

GEARS (515L-515S)

CODE REV

04B_1_14105

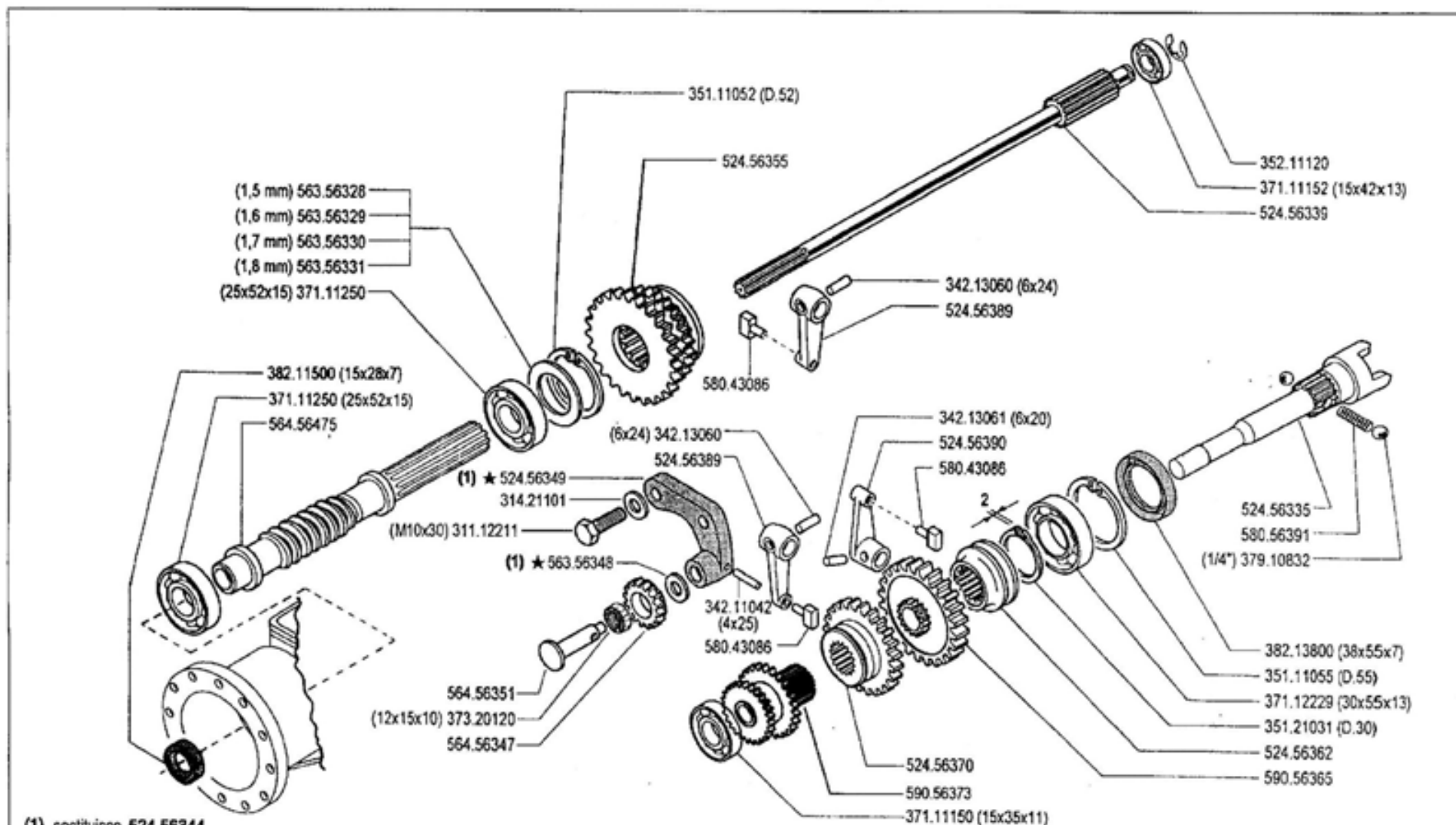

(1) sostituisce 524.56344

FERRARI

500 serie 95

INGRANAGGI CAMBIO (515L - 515S)

GEARS
ENGRANAJES

ENGRANAGES
ZÄHRÄDER

DALLA MACCHINA
DE LA MAQUINA
DE LA MACHINE
FROM THE MACHINE
AB DER MASCHINE

AGGIORNAMENTO
REVISION
MISE A JOUR
APLAZAMIENTO
ANPASSUNG

04 B 1

Rev.

9/2000

★N

FIN

Pos.	Code	Q.ty	Description	Notes
58056391	58056391	0	SPRING	
59056365	59056365	0	PTO GEAR	
59056373	59056373	0	DOUBLE GEAR	

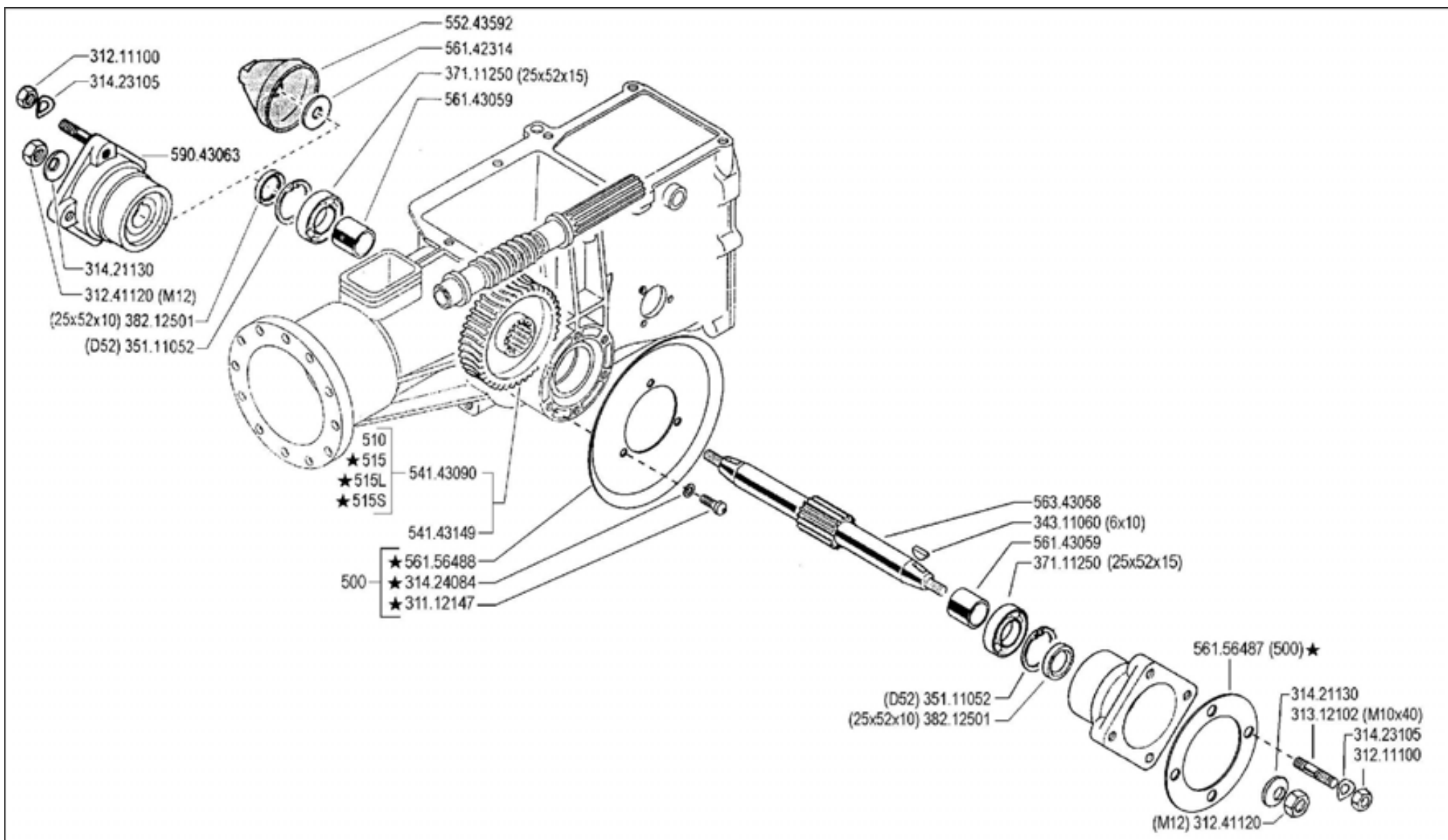

FERRARI

500 serie 95

ASSE RUOTE (500 - 510 - 515 - 515L - 515S - 520)

WHEELS AXLE
EJE RUEDAS

ESSIEU ROUES
RADACHSE

DALLA MACCHINA
DE LA MAGINA
DE LA MACHINE
FROM THE MACHINE
AB DER MASCHINE

AGGIORNAMENTO
REVISION
MISE A JOUR
APLAZAMIENTO
ANPASSUNG

★N.

05

Rev.
02

1/2000

28/86

Pos.	Code	Q.ty	Description	Notes
31112147	31112147	0	SCREW TE M8X18 UNI 5739 8G	
31211100	31211100	0	NUT M10	
31241120	31241120	0	SELFLOCK NUT M12	
31312102	31312102	0	STUD BOLT M10X40X24X12	
31421130	31421130	0	WASHER	
31423105	31423105	0	SPRING WASHER 10,5	
31424084	31424084	0	SPRING WASHER 8,4	
34311060	34311060	0	KEY 6X10 UNI 6606	
35111052	35111052	0	SEEGER RING I 52 DIN 472	
37111250	37111250	0	BEARING	
38212501	38212501	0	OIL SEAL 25X52X10	
54143090	54143090	0	CROWN WHEEL	
54143149	54143149	0	CROWN WHEEL	
55243592	55243592	0	CAP	
56142314	56142314	0	WASHER 12,5x34/4	
56143059	56143059	0	SPACER	
56156487	56156487	0	SPACER	
56156488	56156488	0	GUARD	
56343058	56343058	0	AXLE SHAFT	
59043063	59043063	0	WHEEL HUB	

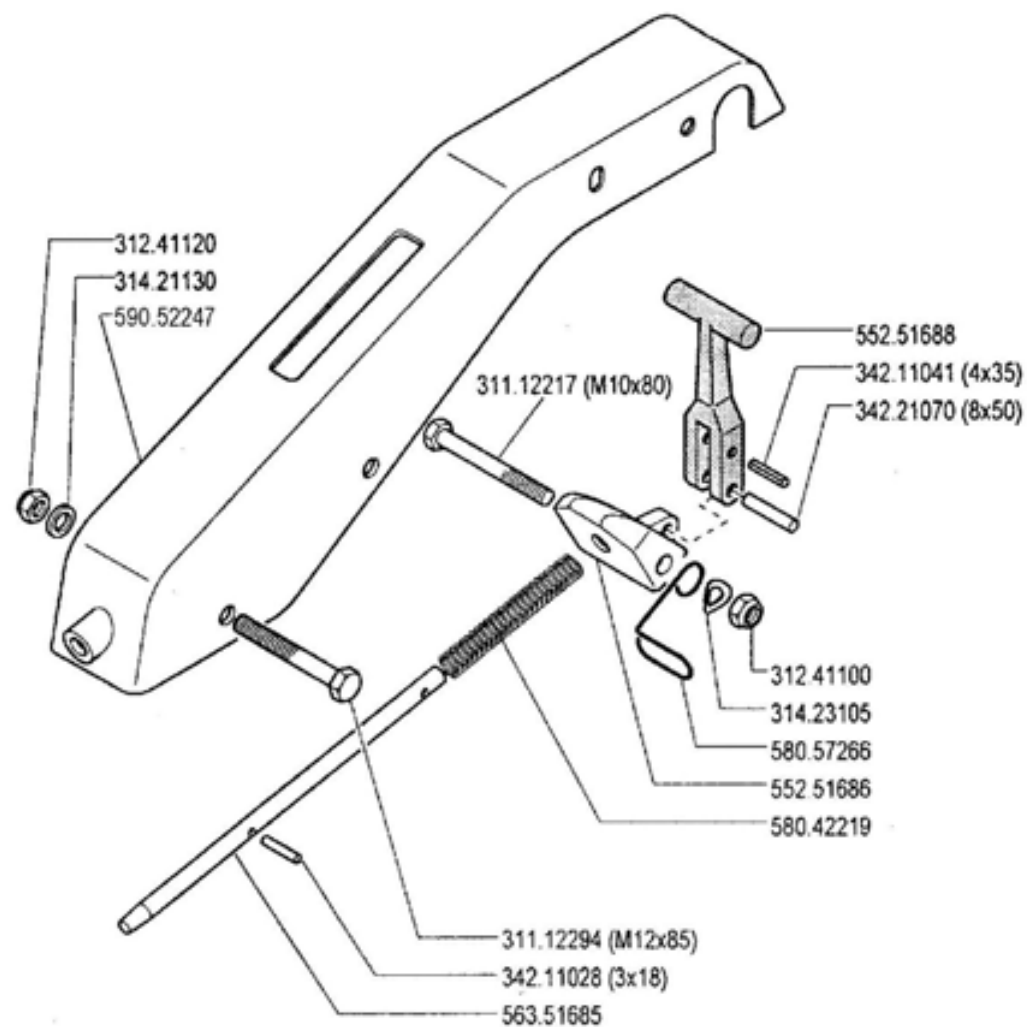

FERRARI

500 serie 95

PIANTONE (515 - 515L - 515S)

STEERING COLUMN
 COLUMNA

PLANTON
 LENKSÄULE

DALLA MACCHINA
 DE LA MAGINA
 DE LA MACHINE
 FROM THE MACHINE
 AB DER MASCHINE

N.

07 A 00

1/2000

Wid

ZENIT

Pos.	Code	Q.ty	Description	Notes
31112217	31112217	0	SCREW TE M10X80 UNI 5737	
31112294	31112294	0	SCREW TE M12X85 UNI 5737	
31241100	31241100	0	SELFLOCK NUT M10 6S	
31241120	31241120	0	SELFLOCK NUT M12	
31421130	31421130	0	WASHER	
31423105	31423105	0	SPRING WASHER 10,5	
34211028	34211028	0	ROLL PIN	
34211041	34211041	0	ROLL PIN	
34221070	34221070	0	CYLINDRICAL PLUG 8X50 UNI 1707	
55251686	55251686	0	LEVER BEARING	
55251688	55251688	0	LEVER	
56351685	56351685	0	ROD	
58042219	58042219	0	SPRING	
58057266	58057266	0	HOLDER	
59052247	59052247	0	HANDLE BAR COLUMN	

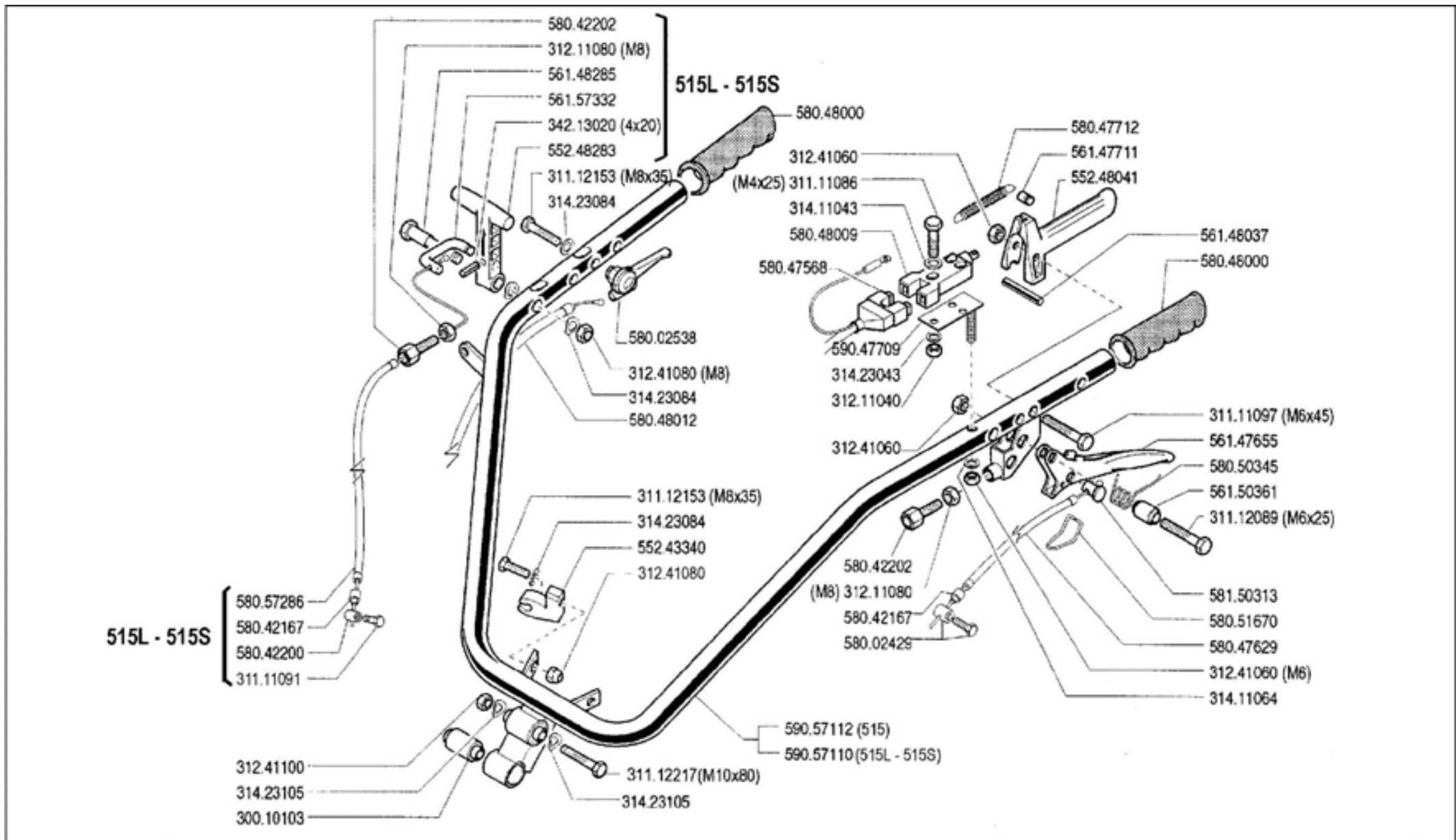

	500 serie 95	MANUBRIO (515 - 515L - 515S)		DALLA MACCHINA DE LA MAGINA DE LA MACHINE FROM THE MACHINE AB DER MASCHINE	N.	08 A 00	1/2000	Vid
		HANDLEBAR MANILLAR	MANCHERON LENKER					

Pos.	Code	Q.ty	Description	Notes
30010103	30010103	0	SILENT-BLOCK 10,2X30X45X60,5	
31111086	31111086	0	SCREW TE M4X25 UNI 5739 8G	
31111091	31111091	0	SCREW E M6X14 UNI 5739 8G	
31111097	31111097	0	SCREW TE M6X45 UNI 5737 8G	
31112089	31112089	0	SCREW TE M6X25 UNI 5739 8G	
31112153	31112153	0	SCREW TE M8X35 UNI 5739 8G	
31112217	31112217	0	SCREW TE M10X80 UNI 5737	
31211040	31211040	0	NUT M4	
31211080	31211080	0	NUT M8	
31241060	31241060	0	SELFLOCK NUT M6	
31241080	31241080	0	SELFLOCK NUT M8	
31241100	31241100	0	SELFLOCK NUT M10 6S	
31411043	31411043	0	WASHER 4,3X9	
31411064	31411064	0	WASHER 6,4x12,5	
31423043	31423043	0	SPRING WASHER 4,3	
31423084	31423084	0	SPRING WASHER 8,4	
31423105	31423105	0	SPRING WASHER 10,5	
34213020	34213020	0	ROLL PIN	
55243340	55243340	0	SUPPORT	
55248041	55248041	0	LEVER	
55248283	55248283	0	COMMAND LEVER	
56147655	56147655	0	CLUTCH LEVER	
56147711	56147711	0	PIN	
56148037	56148037	0	LEVER STOP	
56148285	56148285	0	PIN	
56150361	56150361	0	SPACER	
56157332	56157332	0	U BOLT	
58002429	58002429	0	CLAMPING SCREW	
58002538	58002538	0	COMMAND LEVER	
58042167	58042167	0	SHEATH TERMINAL	
58042200	58042200	0	CLAMPING SCREW	
58042202	58042202	0	ADJUSTING SCREW	
58047568	58047568	0	WIRING	
58047629	58047629	0	LINE AND SHEATH	

SERIAL

HANDLEBAR (515-515L-515S)

CODE REV

08A_0_14359

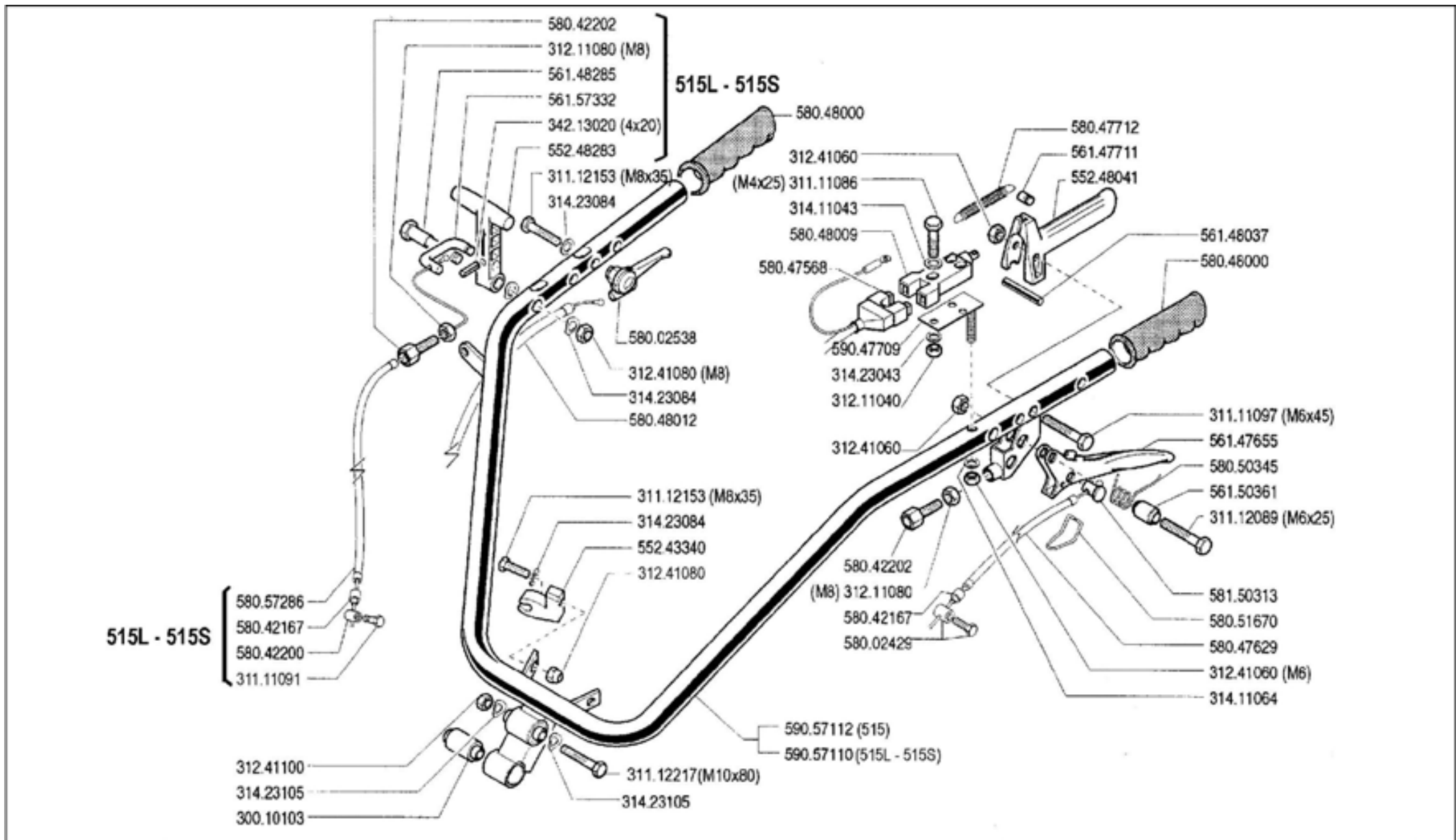

	500 serie 95	MANUBRIO (515 - 515L - 515S)		DALLA MACCHINA DE LA MAQUINA DE LA MACHINE FROM THE MACHINE AB DER MASCHINE	N. _____	08 A 00	Vid 1/2000
		HANDLEBAR MANILLAR	MANCHERON LENKER				

Pos.	Code	Q.ty	Description	Notes
58047712	58047712	0	SPRING	
58048000	58048000	0	KNOB	
58048009	58048009	0	SWITCH	
58048012	58048012	0	LINE AND SHEATH	
58050345	58050345	0	SPRING	
58051670	58051670	0	CLEVIS	
58057286	58057286	0	LINE AND SHEATH	
58150313	58150313	0	CABLE CLAMP	
59047709	59047709	0	SWITCH SUPPORT	
59057110	59057110	0	COMPLETE HANDLE BAR	
59057112	59057112	0	COMPLETE HANDLE BAR	

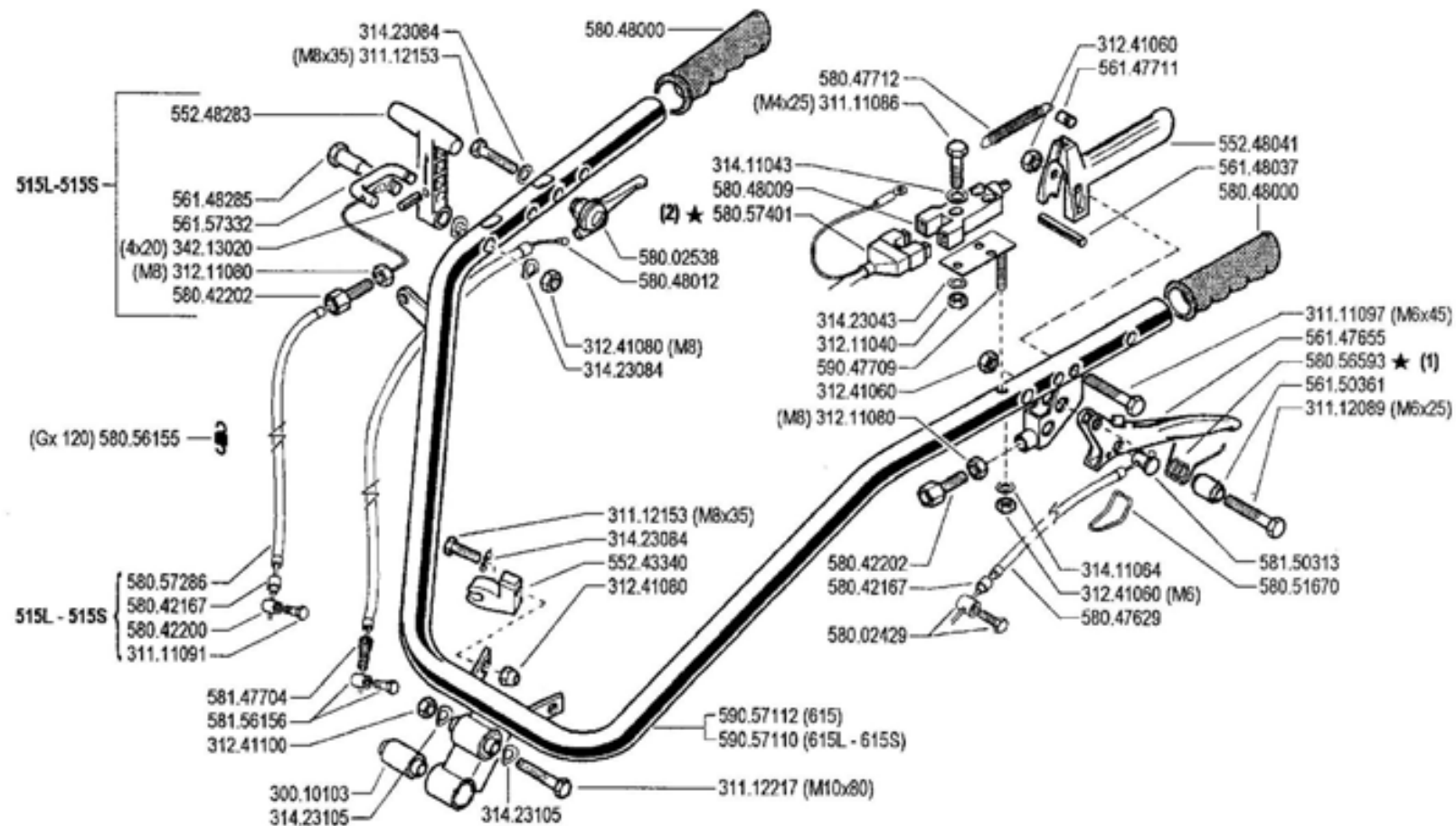

(2) sostituisce 580.47568
 (1) sostituisce 580.50345

FERRARI

500 serie 95

HANDLEBAR
 MANILLAR

MANUBRIO (515 - 515L - 515S)

MANCHERON
 LENKER

DALLA MACCHINA
 DE LA MAQUINA
 DE LA MACHINE
 FROM THE MACHINE
 AB DER MASCHINE

AGGIORNAMENTO
 REVISION
 MISE A JOUR
 APLAZAMIENTO
 ANPASSUNG

★N.

08 A 1

10/2002

Rev.

REV. 08

Pos.	Code	Q.ty	Description	Notes
30010103	30010103	0	SILENT-BLOCK 10,2X30X45X60,5	
31111086	31111086	0	SCREW TE M4X25 UNI 5739 8G	
31111091	31111091	0	SCREW E M6X14 UNI 5739 8G	
31111097	31111097	0	SCREW TE M6X45 UNI 5737 8G	
31112089	31112089	0	SCREW TE M6X25 UNI 5739 8G	
31112153	31112153	0	SCREW TE M8X35 UNI 5739 8G	
31112217	31112217	0	SCREW TE M10X80 UNI 5737	
31211040	31211040	0	NUT M4	
31211080	31211080	0	NUT M8	
31241060	31241060	0	SELFLOCK NUT M6	
31241080	31241080	0	SELFLOCK NUT M8	
31241100	31241100	0	SELFLOCK NUT M10 6S	
31411043	31411043	0	WASHER 4,3X9	
31411064	31411064	0	WASHER 6,4x12,5	
31423043	31423043	0	SPRING WASHER 4,3	
31423084	31423084	0	SPRING WASHER 8,4	
31423105	31423105	0	SPRING WASHER 10,5	
34213020	34213020	0	ROLL PIN	
55243340	55243340	0	SUPPORT	
55248041	55248041	0	LEVER	
55248283	55248283	0	COMMAND LEVER	
56147655	56147655	0	CLUTCH LEVER	
56147711	56147711	0	PIN	
56148037	56148037	0	LEVER STOP	
56148285	56148285	0	PIN	
56150361	56150361	0	SPACER	
56157332	56157332	0	U BOLT	
58002429	58002429	0	CLAMPING SCREW	
58002538	58002538	0	COMMAND LEVER	
58042167	58042167	0	SHEATH TERMINAL	
58042200	58042200	0	CLAMPING SCREW	
58042202	58042202	0	ADJUSTING SCREW	
58047629	58047629	0	LINE AND SHEATH	
58047712	58047712	0	SPRING	

SERIAL

HANDLEBAR (515-515L-515S)

CODE REV

08A_1_14405

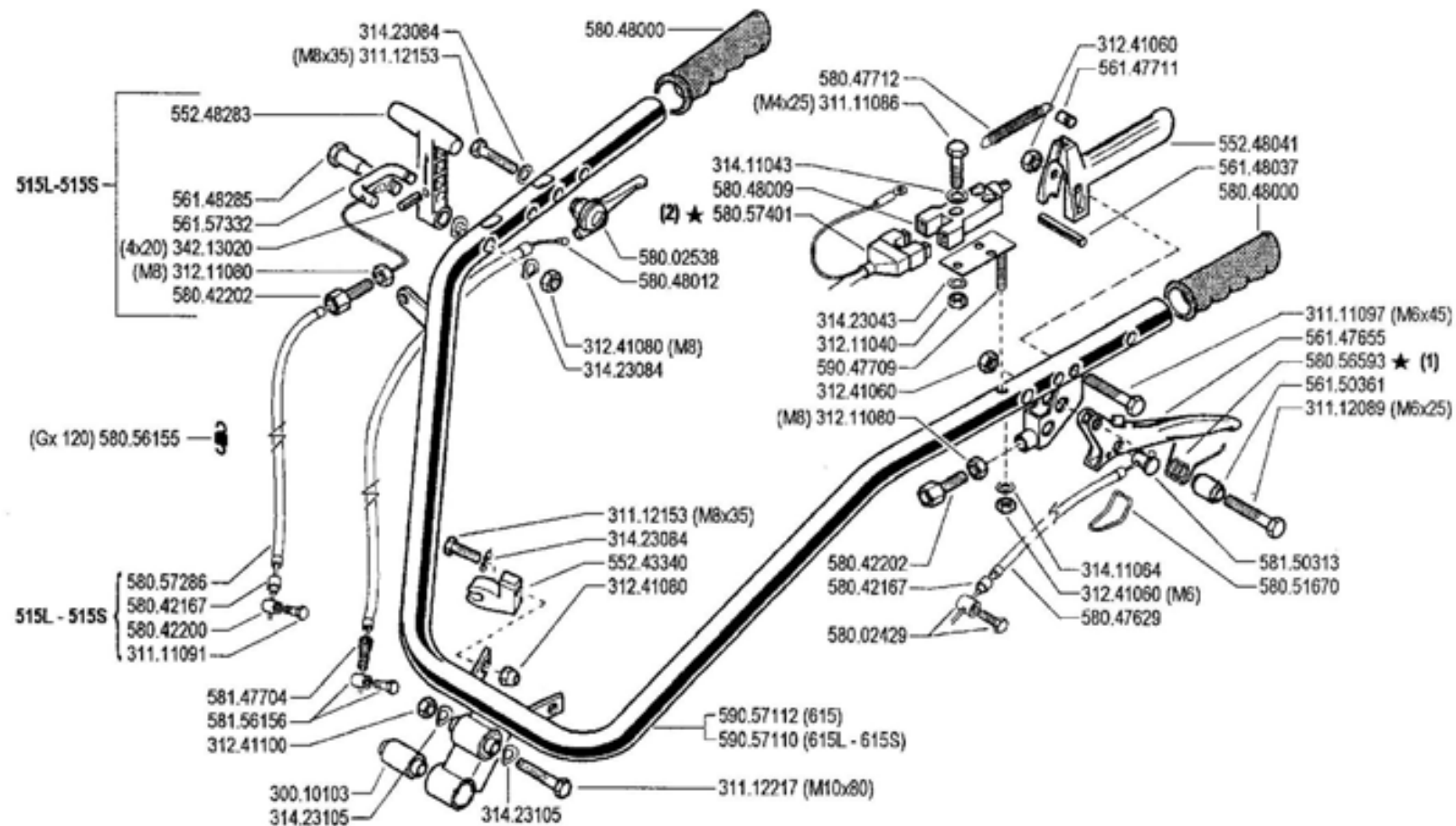

(2) sostituisce 580.47568
 (1) sostituisce 580.50345

FERRARI

500 serie 95

HANDLEBAR
 MANILLAR

MANUBRIO (515 - 515L - 515S)

MANCHERON
 LENKER

DALLA MACCHINA
 DE LA MAQUINA
 DE LA MACHINE
 FROM THE MACHINE
 AB DER MASCHINE

AGGIORNAMENTO
 REVISION
 MISE A JOUR
 APLAZAMIENTO
 ANPASSUNG

08 A 1

10/2002

★N

REV. 1

Pos.	Code	Q.ty	Description	Notes
58048000	58048000	0	KNOB	
58048009	58048009	0	SWITCH	
58048012	58048012	0	LINE AND SHEATH	
58051670	58051670	0	CLEVIS	
58056155	58056155	0	RESTORING SPRING	Utilizzato con motore GX270
58056593	58056593	0	SPRING	
58057286	58057286	0	LINE AND SHEATH	
58057401	58057401	0	WIRING	
58147704	58147704	0	ADJUSTING SCREW	
58150313	58150313	0	CABLE CLAMP	
58156156	58156156	0	TERMINAL	
59047709	59047709	0	SWITCH SUPPORT	
59057110	59057110	0	COMPLETE HANDLE BAR	
59057112	59057112	0	COMPLETE HANDLE BAR	

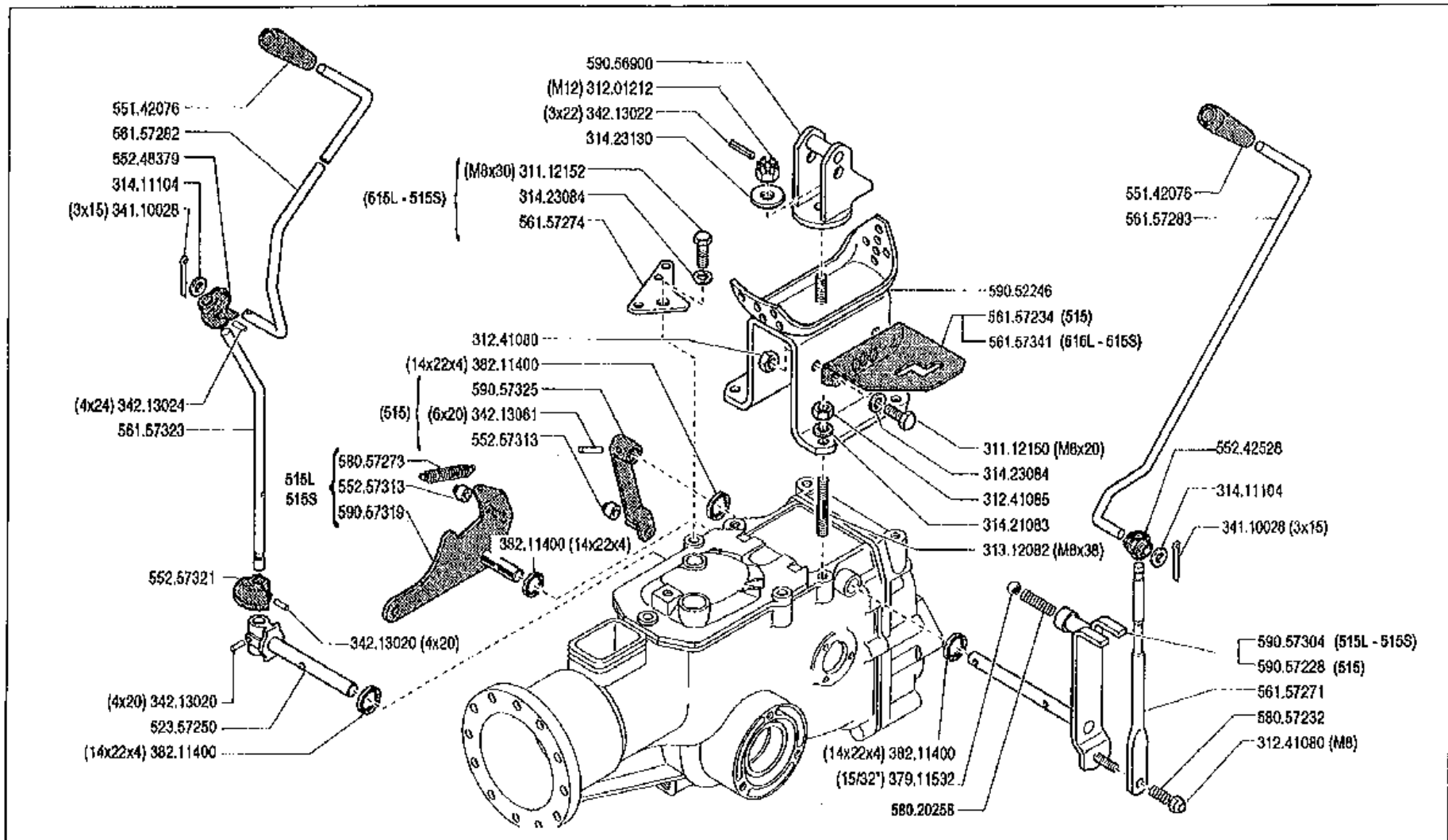

	500 serie 95	COMANDI (515 - 515L - 515S)		DALLA MACCHINA DE LA MAQUINA DE LA MACHINE FROM THE MACHINE AB DER MASCHINE	Mod. 09 A 00
		CONTROLS MANDOS	COMMANDES ANTRIEBE		

25556

Pos.	Code	Q.ty	Description	Notes
31112150	31112150	0	SCREW TE M8X20 UNI 5739 8G	
31112152	31112152	0	SCREW TE M8X30 UNI 5739 8G	
31201212	31201212	0	NUT M12	
31241080	31241080	0	SELFLOCK NUT M8	
31241085	31241085	0	SELFLOCK NUT M8 6S	
31312082	31312082	0	STUD BOLT M8X38X14X20	
31411104	31411104	0	WASHER 10,5x18	
31421083	31421083	0	WASHER	
31423084	31423084	0	SPRING WASHER 8,4	
31423130	31423130	0	SPRING WASHER 13	
34110028	34110028	0	SPLIT PIN	
34213020	34213020	0	ROLL PIN	
34213022	34213022	0	ROLL PIN	
34213024	34213024	0	ROLL PIN	
34213061	34213061	0	ROLL PIN	
37911532	37911532	0	BALL 15/32	
38211400	38211400	0	OIL SEAL 14X22X4	
52357250	52357250	0	PIN	
55142076	55142076	0	KNOB	
55242528	55242528	0	JOINT	
55248379	55248379	0	JOINT	
55257313	55257313	0	ROLLER	
55257321	55257321	0	STOP	
56157234	56157234	0	GEAR SELECTOR	
56157271	56157271	0	COMMAND LEVER	
56157274	56157274	0	SQUARE	
56157282	56157282	0	ROD	
56157283	56157283	0	GEARSHIFT ROD	
56157323	56157323	0	PTO LEVER	
56157341	56157341	0	GEAR SELECTOR	
58020258	58020258	0	SPRING	
58057232	58057232	0	SPRING	
58057273	58057273	0	SPRING	
59052246	59052246	0	SUMP	

SERIAL

CONTROLS (515-515L-515S)

CODE REV

09A_0_14579

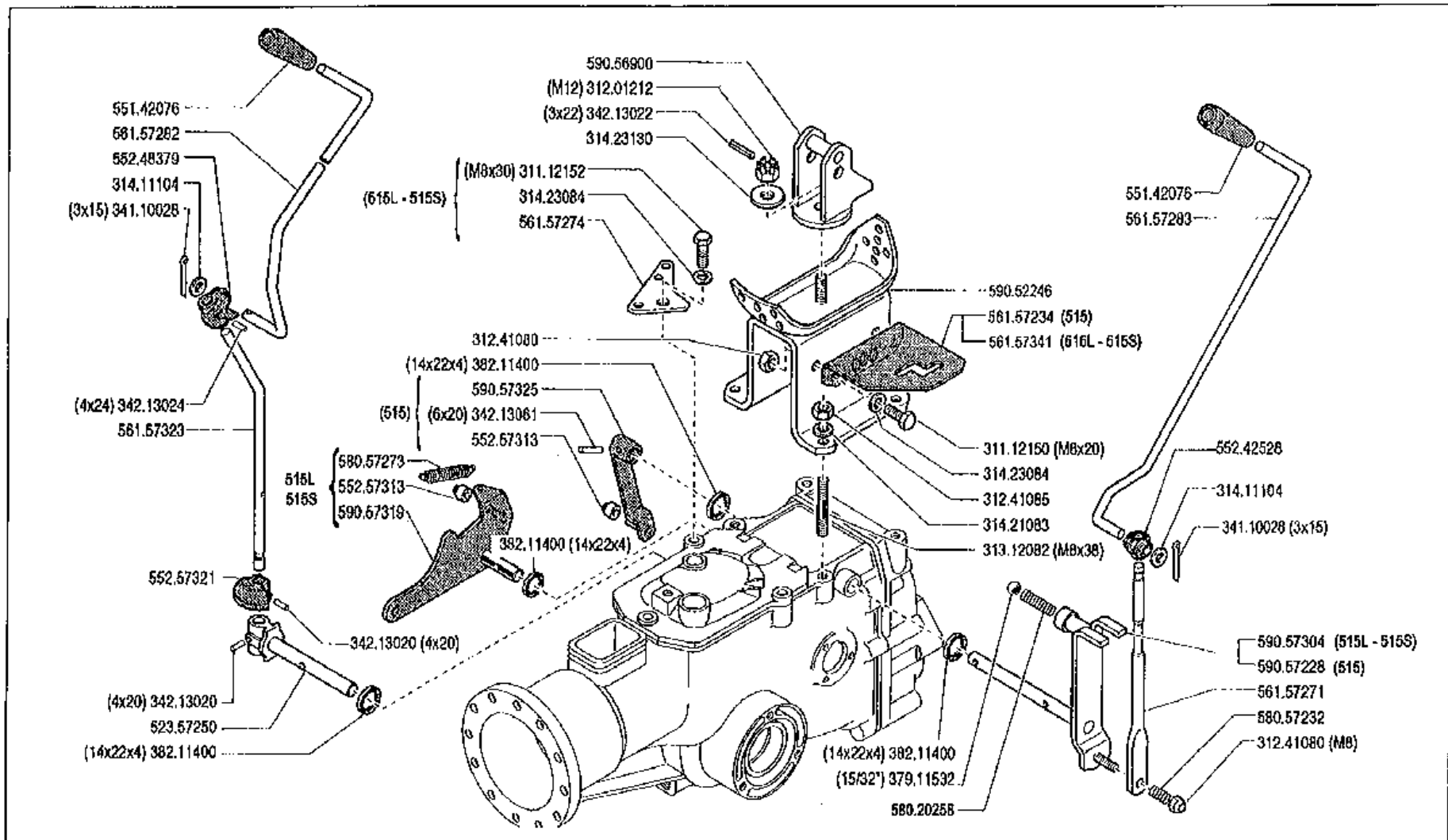

	500 serie 95	COMANDI (515 - 515L - 515S)		DALLA MACCHINA DE LA MAQUINA DE LA MACHINE FROM THE MACHINE AB DER MASCHINE	Mod. 09 A 00
		CONTROLS MANDOS	COMMANDES ANTRIEBE		

25556

Pos.	Code	Q.ty	Description	Notes
59056900	59056900	0	SUPPORT	
59057228	59057228	0	GEAR LEVER	
59057304	59057304	0	GEAR LEVER	
59057319	59057319	0	LEVER	
59057325	59057325	0	LEVER	

	A	B	C
3.50 - 8" (500)	391.13502	394.13502	580.52325
3.50 - 8"	391.13502	394.13502	580.52326
4.00 - 8"	391.14008	394.14008	580.52326
4.0 - 10"	391.14010	394.14010	580.52327
5.0 - 10"	391.15010	394.15010	580.52327
21 x 11.00 - 8"	391.13501	TUBELESS	580.52274 ★ (1)

★ 924.57794

KIT GEMELLAGGIO PER 4.0-10" / 5.0-10"
 TWINNING KIT FOR 4.0-10" / 5.0-10"
 JUMELAGE KIT POUR 4.0-10" / 5.0-10"
 KIT GEMELOS POR 4.0-10" / 5.0-10"
 ZWILLINGSKIT 4.0-10" / 5.0-10"

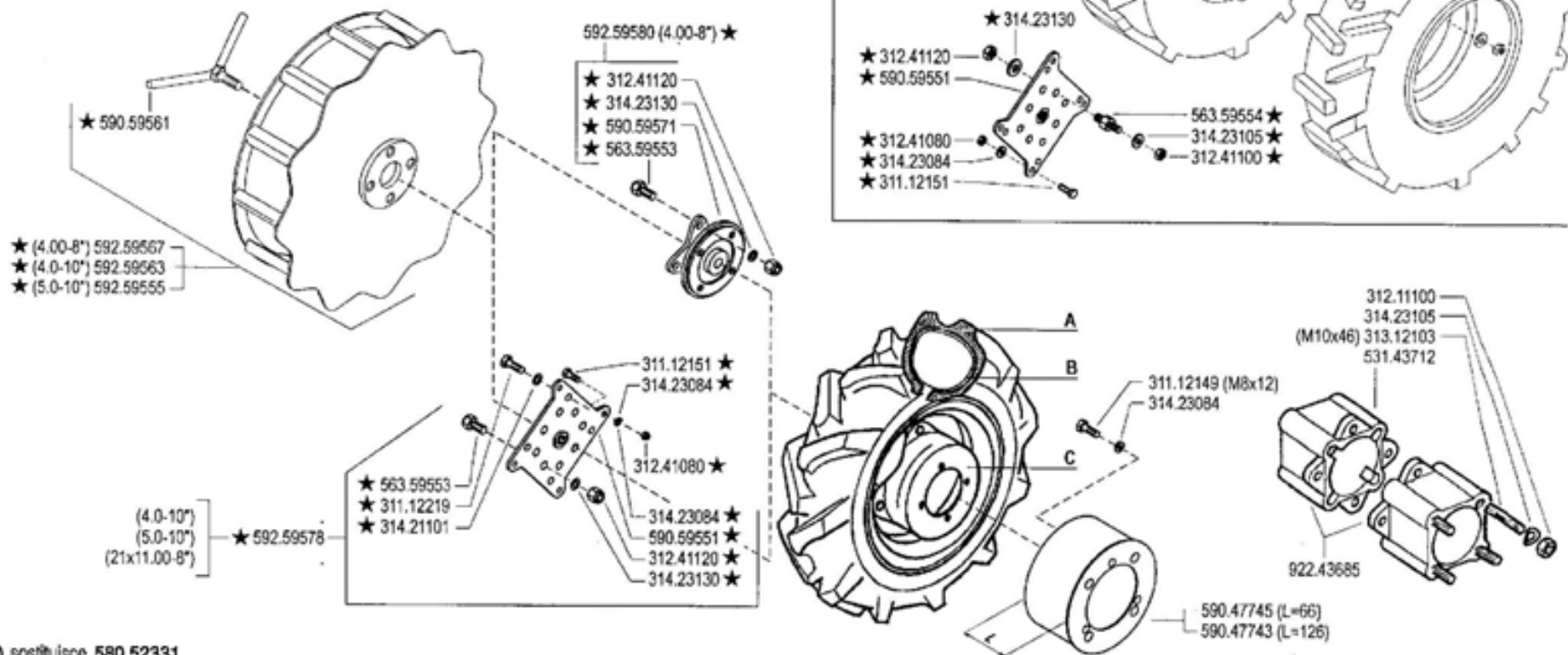

(1) sostituisce 580.52331

FERRARI

500 serie 95

RUOTE

WHEELS
 RUEDAS

ROUES
 RÄDER

DALLA MACCHINA
 DE LA MAQUINA
 DE LA MACHINE
 FROM THE MACHINE
 AB DER MASCHINE

AGGIORNAMENTO

REVISION

MISE A JOUR

APLAZAMIENTO

ANPASSUNG

11

Rev.
 3

12/2003

★ N.

71/06

Pos.	Code	Q.ty	Description	Notes
31112149	31112149	0	SCREW TE M8X12 UNI 5739 8G	
31112151	31112151	0	SCREW TE M8X25 UNI 5739 8G	
31112219	31112219	0	SCREW TE M10X25 UNI 5739	
31211100	31211100	0	NUT M10	
31241080	31241080	0	SELFLOCK NUT M8	
31241100	31241100	0	SELFLOCK NUT M10 6S	
31241120	31241120	0	SELFLOCK NUT M12	
31312103	31312103	0	STUD BOLT M10X46X24X16	
31421101	31421101	0	WASHER	
31423084	31423084	0	SPRING WASHER 8,4	
31423105	31423105	0	SPRING WASHER 10,5	
31423130	31423130	0	SPRING WASHER 13	
39113501	39113501	0	TYRE 21X11.00-8	
39113502	39113502	0	TYRE 3.50-8 2PR	
39114008	39114008	0	TYRE 4.00-8 2PR	
39114010	39114010	0	TYRE 4.0-10 2PR	
39115010	39115010	0	TYRE 5.00-10 2PR	
39413502	39413502	0	INNER TUBE	
39414008	39414008	0	INNER TUBE	
39414010	39414010	0	INNER TUBE	
39415010	39415010	0	INNER TUBE	
53143712	53143712	0	SPACER	
56359553	56359553	0	PIN	
56359554	56359554	0	PIN	
58052274	58052274	0	RIM	
58052325	58052325	0	RIM	
58052326	58052326	0	RIM	
58052327	58052327	0	RIM	
59047743	59047743	0	HUBCOVER	
59047745	59047745	0	HUBCOVER	
59059551	59059551	0	FLANGE	
59059561	59059561	0	SCREW	
59059571	59059571	0	FLANGE	
59259555	59259555	0	SUPER-BITE WHEEL X 5.00-10	

SERIAL

WHEELS

CODE REV

011_3_13744

	A	B	C
3.50 - 8" (500)	391.13502	394.13502	580.52325
3.50 - 8"	391.13502	394.13502	580.52326
4.00 - 8"	391.14008	394.14008	580.52326
4.0 - 10"	391.14010	394.14010	580.52327
5.0 - 10"	391.15010	394.15010	580.52327
21 x 11.00 - 8"	391.13501	TUBELESS	580.52274 ★ (1)

★ 924.57794

KIT GEMELLAGGIO PER 4.0-10" / 5.0-10"
 TWINNING KIT FOR 4.0-10" / 5.0-10"
 JUMELAGE KIT POUR 4.0-10" / 5.0-10"
 KIT GEMELOS POR 4.0-10" / 5.0-10"
 ZWILLINGSKIT 4.0-10" / 5.0-10"

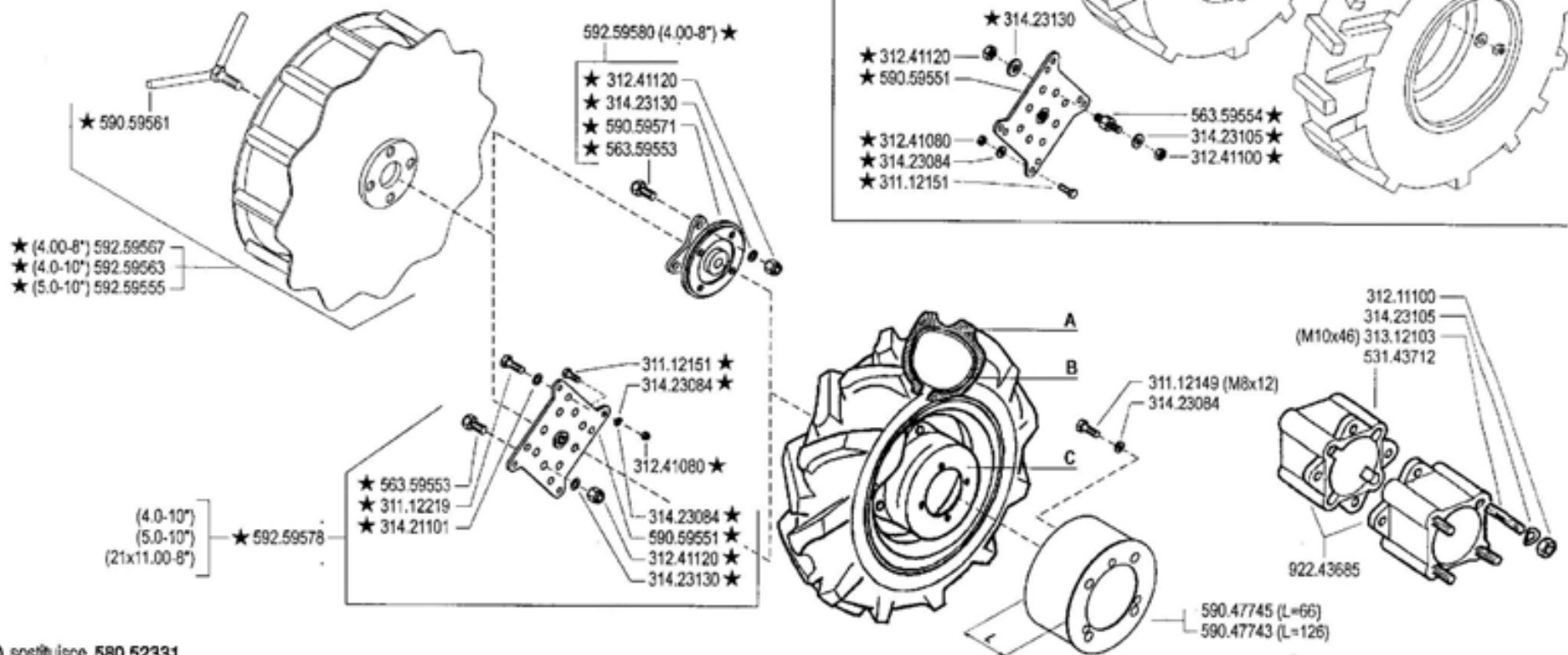

(1) sostituisce 580.52331

FERRARI

500 serie 95

RUOTE

WHEELS
 RUEDAS

ROUES
 RÄDER

DALLA MACCHINA
 DE LA MAQUINA
 DE LA MACHINE
 FROM THE MACHINE
 AB DER MASCHINE

AGGIORNAMENTO

REVISION

MISE A JOUR

APLAZAMIENTO

ANPASSUNG

11

Rev.
 3

12/2003

★ N.

71/06

Pos.	Code	Q.ty	Description	Notes
59259563	59259563	0	WHEEL	
59259567	59259567	0	WHEEL	
59259578	59259578	0	FLANGE KIT	
59259580	59259580	0	FLANGE KIT	
92243685	92243685	0	PAIR WHEEL SPACERS 6 CM	
92457794	92457794	0	ADAPTOR PLATES 10 WHEELS (PAIR)	

500

580.52018

FERRARI

580.52019

FERRARI

580.52020

520

580.52021

520

580.52022

530

580.52023

530

580.52024

510

580.52033

510

580.52034



580.46901



580.46912

**FRIZIONE
EMBRAYAGE
EMBRAGUE**

580.46903

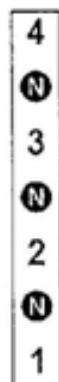

580.57698



580.57678



580.46913



580.57712



580.46902



580.46909

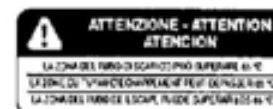

580.46910



580.57722



580.57724

FERRARI

500 serie 95

ADHESIVOS
AUTOCOLLANTS

ADESIVI

STICKERS
AUFKLEBES

DALLA MACCHINA
DE LA MAQUINA
DE LA MACHINE
FROM THE MACHINE
AB DER MASCHINE

N.

12.00

9/1997

Pos.	Code	Q.ty	Description	Notes
58046901	58046901	0	DECAL	
58046902	58046902	0	DECAL	
58046903	58046903	0	DECAL	
58046909	58046909	0	DECAL	
58046910	58046910	0	DECAL	
58046912	58046912	0	DECAL	
58046913	58046913	0	DECAL	
58052018	58052018	0	DECAL	
58052019	58052019	0	DECAL	
58052020	58052020	0	DECAL	
58052021	58052021	0	DECAL	
58052022	58052022	0	DECAL	
58052023	58052023	0	DECAL	
58052024	58052024	0	DECAL	
58052033	58052033	0	DECAL	
58052034	58052034	0	DECAL	
58057678	58057678	0	DECAL	
58057698	58057698	0	DECAL	
58057712	58057712	0	DECAL	
58057722	58057722	0	DECAL	
58057724	58057724	0	DECAL	



580.52019 (L= 87)
 580.52029 (L= 140) ★
 580.52020 (L= 174)



580.52018



580.52033



580.52021



580.52023



580.52034



580.52022



580.52024



580.52144 ★



580.52146 ★



580.52148 ★



580.52145 ★



580.52147 ★



580.52149 ★

FERRARI

500 serie **95**

STICKERS
ADHESIVOS

ADESIVI

AUTOCOLLANTS
AUFKLEBES

DALLA MACCHINA
DE LA MAQUINA
DE LA MACHINE
FROM THE MACHINE
AB DER MASCHINE

★N.

AGGIORNAMENTO
REVISION
MISE A JOUR
APLAZAMIENTO
ANPASSUNG

12

Vol.
01

1/2000

ZEKNE

Pos.	Code	Q.ty	Description	Notes
58052018	58052018	0	DECAL	
58052019	58052019	0	DECAL	
58052020	58052020	0	DECAL	
58052021	58052021	0	DECAL	
58052022	58052022	0	DECAL	
58052023	58052023	0	DECAL	
58052024	58052024	0	DECAL	
58052029	58052029	0	DECAL	
58052033	58052033	0	DECAL	
58052034	58052034	0	DECAL	
58052144	58052144	0	DECAL	
58052145	58052145	0	DECAL	
58052146	58052146	0	DECAL	
58052147	58052147	0	DECAL	
58052148	58052148	0	DECAL	
58052149	58052149	0	DECAL	

510 580.52033

510 580.52034



580.52019 (L= 87)
580.52029 (L= 140)
580.52020 (L= 174)

515 580.52144

515 580.52145

520 580.52021

520 580.52022

500 580.52018

530 580.52023

530 580.52024

515 L 580.52146

530 S 580.52150 ★

530 S 580.52151 ★

515 L 580.52147

530 S2 580.52154 ★

530 S2 580.52155 ★

515 S 580.52148

515 S 580.52149

FERRARI

500 serie 95

ADESIVI

STICKERS
ADHESIVOS

AUTOCOLLANTS
AUFKLEBES

DALLA MACCHINA
DE LA MAQUINA
DE LA MACHINE
FROM THE MACHINE
AB DER MASCHINE

AGGIORNAMENTO

REVISION

MISE A JOUR

AFILAZAMENTO

ANPASSUNG

12

Rev.
2

10/2001

★N.

23/01/01

Pos.	Code	Q.ty	Description	Notes
58052018	58052018	0	DECAL	
58052019	58052019	0	DECAL	
58052020	58052020	0	DECAL	
58052021	58052021	0	DECAL	
58052022	58052022	0	DECAL	
58052023	58052023	0	DECAL	
58052024	58052024	0	DECAL	
58052029	58052029	0	DECAL	
58052033	58052033	0	DECAL	
58052034	58052034	0	DECAL	
58052144	58052144	0	DECAL	
58052145	58052145	0	DECAL	
58052146	58052146	0	DECAL	
58052147	58052147	0	DECAL	
58052148	58052148	0	DECAL	
58052149	58052149	0	DECAL	
58052150	58052150	0	DECAL	
58052151	58052151	0	DECAL	
58052154	58052154	0	DECAL	
58052155	58052155	0	DECAL	



580.57698



580.46912



580.46913



580.57772 ★



580.57771 ★



580.57767 ★



580.57768 ★



580.57678



580.57712



580.57676

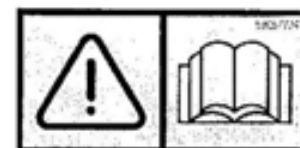

580.57724



580.57770 ★



580.57722

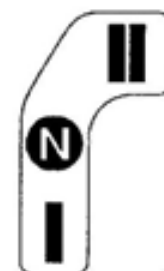

580.57732

FERRARI

500 serie 95

ADESIVI

STICKERS
ADHESIVOS

AUTOCOLLANTS
AUFKLEBES

DALLA MACCHINA
DE LA MAQUINA
DE LA MACHINE
FROM THE MACHINE
AB DER MASCHINE

AGGIORNAMENTO
REVISION
MISE A JOUR
APLAZAMIENTO
ANPASSUNG

13

12/2003

Rev.
1

★N

F004

Pos.	Code	Q.ty	Description	Notes
58046912	58046912	0	DECAL	
58046913	58046913	0	DECAL	
58057676	58057676	0	DECAL	
58057678	58057678	0	DECAL	
58057698	58057698	0	DECAL	
58057712	58057712	0	DECAL	
58057722	58057722	0	DECAL	
58057724	58057724	0	DECAL	
58057732	58057732	0	DECAL	
58057767	58057767	0	DECAL	
58057768	58057768	0	DECAL	
58057770	58057770	0	DECAL	
58057771	58057771	0	DECAL	
58057772	58057772	0	DECAL	

4

N

PERICOLO DI RIALZAMENTO
DANGER OF CAPSIZING
GEFAHR DES UMSCHLAGENS
VEHRISCHLAGENSGEFAHR
PELIGRO DE VUELCO

580.57722



580.57724



580.46909

3

N

2

N

1

580.57698

N



580.57712



580.46902

**ATTENZIONE - ATTENTION
ATENCIÓN**

LA ZONA DEL TUBO DI SCARICO PUO' SUPERARE 65 °C
LA ZONE DU TUYAU D'ECHAPPEMENT PEUT DEPASSER 65 °C
LA ZONA DEL TUBO DE ESCAPE PUEDE SUPERAR 65 °C

580.46910

580.57698

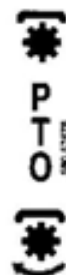

580.57678

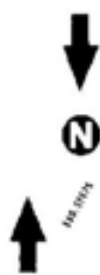

580.57676 ★



580.46901

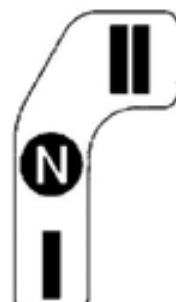

580.57732 ★

**FRIZIONE
EMBRAYAGE
EMBRAGUE**

580.46903



580.46912



580.46913

FERRARI

500 serie 95

ADESIVI

STICKERS
ADHESIVOS

AUTOCOLLANTS
AUFKLEBES

DALLA MACCHINA
DE LA MAQUINA
FROM THE MACHINE
AB DER MASCHINE

★ N

13

Mod.
00

1/2000

2016

Pos.	Code	Q.ty	Description	Notes
58046901	58046901	0	DECAL	
58046902	58046902	0	DECAL	
58046903	58046903	0	DECAL	
58046909	58046909	0	DECAL	
58046910	58046910	0	DECAL	
58046912	58046912	0	DECAL	
58046913	58046913	0	DECAL	
58057676	58057676	0	DECAL	
58057678	58057678	0	DECAL	
58057698	58057698	0	DECAL	
58057712	58057712	0	DECAL	
58057722	58057722	0	DECAL	
58057724	58057724	0	DECAL	
58057732	58057732	0	DECAL	

SPARE PARTS INSTANCE INDEX





SPARE PARTS INSTANCE INDEX

Code	Parts Table	Pos.	Q.ty	Code	Parts Table	Pos.	Q.ty	Code	Parts Table	Pos.	Q.ty
30010103	08A_0_14359	30010103	0	31112210	03A_1_13913	31112210	0	31241085	03A_1_13913	31241085	0
	08A_1_14405	30010103	0		03A_2_13945	31112210	0		03A_2_13945	31241085	0
30040001	03A_1_13913	30040001	0	31112211	04B_0_14068	31112211	0		09A_0_14579	31241085	0
	03A_2_13945	30040001	0		04B_1_14105	31112211	0	31241100	011_3_13744	31241100	0
30040133	03A_1_13913	30040133	0	31112217	07A_0_14343	31112217	0		07A_0_14343	31241100	0
	03A_2_13945	30040133	0		08A_0_14359	31112217	0		08A_0_14359	31241100	0
31100003	002_2_12761	31100003	0		08A_1_14405	31112217	0		08A_1_14405	31241100	0
	002_3_12779	31100003	0	31112219	011_3_13744	31112219	0	31241120	005_2_13039	31241120	0
31100015	002_0_12722	31100015	0	31112294	07A_0_14343	31112294	0		011_3_13744	31241120	0
	002_1_12741	31100015	0	31132562	03A_1_13913	31132562	0		07A_0_14343	31241120	0
	002_3_12779	31100015	0		03A_2_13945	31132562	0	31312082	03A_1_13913	31312082	0
31100786	002_0_12722	31100786	0	31152103	03A_1_13913	31152103	0		03A_2_13945	31312082	0
	002_1_12741	31100786	0		03A_2_13945	31152103	0		09A_0_14579	31312082	0
	002_2_12761	31100786	0	31201212	09A_0_14579	31201212	0	31312083	002_1_12741	31312083	0
	002_3_12779	31100786	0	31211040	08A_0_14359	31211040	0		002_2_12761	31312083	0
31111086	08A_0_14359	31111086	0		08A_1_14405	31211040	0		002_3_12779	31312083	0
	08A_1_14405	31111086	0	31211080	002_0_12722	31211080	0	31312086	03A_1_13913	31312086	0
31111090	03A_1_13913	31111090	0		002_1_12741	31211080	0		03A_2_13945	31312086	0
	03A_2_13945	31111090	0		002_2_12761	31211080	0	31312088	002_0_12722	31312088	0
31111091	08A_0_14359	31111091	0		002_3_12779	31211080	0		002_1_12741	31312088	0
	08A_1_14405	31111091	0		08A_0_14359	31211080	0		002_2_12761	31312088	0
31111097	08A_0_14359	31111097	0		08A_1_14405	31211080	0		002_3_12779	31312088	0
	08A_1_14405	31111097	0	31211100	005_2_13039	31211100	0	31312094	03A_1_13913	31312094	0
31112089	08A_0_14359	31112089	0		011_3_13744	31211100	0		03A_2_13945	31312094	0
	08A_1_14405	31112089	0	31221121	03A_1_13913	31221121	0	31312102	005_2_13039	31312102	0
31112147	005_2_13039	31112147	0		03A_2_13945	31221121	0	31312103	011_3_13744	31312103	0
31112149	011_3_13744	31112149	0	31241060	08A_0_14359	31241060	0	31312124	03A_1_13913	31312124	0
31112150	09A_0_14579	31112150	0		08A_1_14405	31241060	0		03A_2_13945	31312124	0
31112151	011_3_13744	31112151	0	31241080	011_3_13744	31241080	0	31312125	03A_1_13913	31312125	0
31112152	03A_1_13913	31112152	0		03A_1_13913	31241080	0		03A_2_13945	31312125	0
	03A_2_13945	31112152	0		03A_2_13945	31241080	0	31411043	08A_0_14359	31411043	0
	09A_0_14579	31112152	0		08A_0_14359	31241080	0		08A_1_14405	31411043	0
31112153	08A_0_14359	31112153	0		08A_1_14405	31241080	0	31411064	08A_0_14359	31411064	0
	08A_1_14405	31112153	0		09A_0_14579	31241080	0		08A_1_14405	31411064	0



SPARE PARTS INSTANCE INDEX

Code	Parts Table	Pos.	Q.ty	Code	Parts Table	Pos.	Q.ty	Code	Parts Table	Pos.	Q.ty
31411104	09A_0_14579	31411104	0	31423130	011_3_13744	31423130	0	37111250	005_2_13039	37111250	0
31421083	03A_1_13913	31421083	0		03A_1_13913	31423130	0		04B_0_14068	37111250	0
	03A_2_13945	31421083	0		09A_0_14579	31423130	0		04B_1_14105	37111250	0
	09A_0_14579	31421083	0	31424084	005_2_13039	31424084	0	37112173	002_0_12722	37112173	0
31421101	011_3_13744	31421101	0	34110028	09A_0_14579	34110028	0		002_1_12741	37112173	0
	03A_1_13913	31421101	0	34211028	07A_0_14343	34211028	0		002_2_12761	37112173	0
	03A_2_13945	31421101	0	34211041	07A_0_14343	34211041	0		002_3_12779	37112173	0
	04B_0_14068	31421101	0	34211042	04B_0_14068	34211042	0	37112229	04B_0_14068	37112229	0
	04B_1_14105	31421101	0		04B_1_14105	34211042	0		04B_1_14105	37112229	0
31421130	005_2_13039	31421130	0	34213020	08A_0_14359	34213020	0	37112231	002_2_12761	37112231	0
	07A_0_14343	31421130	0		08A_1_14405	34213020	0		002_3_12779	37112231	0
31421132	03A_2_13945	31421132	0		09A_0_14579	34213020	0	37112233	002_0_12722	37112233	0
31422064	03A_1_13913	31422064	0	34213022	09A_0_14579	34213022	0		002_1_12741	37112233	0
	03A_2_13945	31422064	0	34213024	09A_0_14579	34213024	0		002_3_12779	37112233	0
31423043	08A_0_14359	31423043	0	34213060	04B_0_14068	34213060	0	37320120	04B_0_14068	37320120	0
	08A_1_14405	31423043	0		04B_1_14105	34213060	0		04B_1_14105	37320120	0
31423084	002_0_12722	31423084	0	34213061	04B_0_14068	34213061	0	37910832	04B_0_14068	37910832	0
	002_1_12741	31423084	0		04B_1_14105	34213061	0		04B_1_14105	37910832	0
	002_2_12761	31423084	0		09A_0_14579	34213061	0	37911532	09A_0_14579	37911532	0
	002_3_12779	31423084	0	34221070	07A_0_14343	34221070	0	38211400	09A_0_14579	38211400	0
	011_3_13744	31423084	0	34311060	005_2_13039	34311060	0	38211500	04B_0_14068	38211500	0
	03A_1_13913	31423084	0	35111052	005_2_13039	35111052	0		04B_1_14105	38211500	0
	03A_2_13945	31423084	0		04B_0_14068	35111052	0	38212501	005_2_13039	38212501	0
	08A_0_14359	31423084	0		04B_1_14105	35111052	0	38213800	04B_0_14068	38213800	0
	08A_1_14405	31423084	0	35111055	04B_0_14068	35111055	0		04B_1_14105	38213800	0
	09A_0_14579	31423084	0		04B_1_14105	35111055	0	39113501	011_3_13744	39113501	0
31423105	002_0_12722	31423105	0	35121031	04B_0_14068	35121031	0	39113502	011_3_13744	39113502	0
	002_1_12741	31423105	0		04B_1_14105	35121031	0	39114008	011_3_13744	39114008	0
	002_3_12779	31423105	0	35211120	04B_0_14068	35211120	0	39114010	011_3_13744	39114010	0
	005_2_13039	31423105	0		04B_1_14105	35211120	0	39115010	011_3_13744	39115010	0
	011_3_13744	31423105	0	37111150	04B_0_14068	37111150	0	39413502	011_3_13744	39413502	0
	07A_0_14343	31423105	0		04B_1_14105	37111150	0	39414008	011_3_13744	39414008	0
	08A_0_14359	31423105	0	37111152	04B_0_14068	37111152	0	39414010	011_3_13744	39414010	0
	08A_1_14405	31423105	0		04B_1_14105	37111152	0	39415010	011_3_13744	39415010	0



SPARE PARTS INSTANCE INDEX

Code	Parts Table	Pos.	Q.ty	Code	Parts Table	Pos.	Q.ty	Code	Parts Table	Pos.	Q.ty
50947833	002_0_12722	50947833	0	53152411	03A_2_13945	53152411	0	56147711	08A_0_14359	56147711	0
	002_1_12741	50947833	0	53156150	002_3_12779	53156150	0		08A_1_14405	56147711	0
	002_2_12761	50947833	0	53156325	03A_1_13913	53156325	0	56147845	002_0_12722	56147845	0
	002_3_12779	50947833	0	53156332	03A_1_13913	53156332	0		002_1_12741	56147845	0
52357250	09A_0_14579	52357250	0	53156342	03A_1_13913	53156342	0		002_2_12761	56147845	0
52447896	002_0_12722	52447896	0	53247468	002_2_12761	53247468	0		002_3_12779	56147845	0
	002_1_12741	52447896	0	53247488	002_3_12779	53247488	0	56147923	03A_1_13913	56147923	0
	002_2_12761	52447896	0	54143090	005_2_13039	54143090	0		03A_2_13945	56147923	0
	002_3_12779	52447896	0	54143149	005_2_13039	54143149	0	56148037	08A_0_14359	56148037	0
52456335	04B_0_14068	52456335	0	55102678	03A_1_13913	55102678	0		08A_1_14405	56148037	0
	04B_1_14105	52456335	0		03A_2_13945	55102678	0	56148285	08A_0_14359	56148285	0
52456339	04B_0_14068	52456339	0	55142076	09A_0_14579	55142076	0		08A_1_14405	56148285	0
	04B_1_14105	52456339	0	55147842	002_0_12722	55147842	0	56150361	08A_0_14359	56150361	0
52456344	04B_0_14068	52456344	0		002_1_12741	55147842	0		08A_1_14405	56150361	0
52456349	04B_1_14105	52456349	0		002_2_12761	55147842	0	56152403	03A_2_13945	56152403	0
52456355	04B_0_14068	52456355	0		002_3_12779	55147842	0	56156487	005_2_13039	56156487	0
	04B_1_14105	52456355	0	55242528	09A_0_14579	55242528	0	56156488	005_2_13039	56156488	0
52456362	04B_0_14068	52456362	0	55243340	08A_0_14359	55243340	0	56157234	09A_0_14579	56157234	0
	04B_1_14105	52456362	0		08A_1_14405	55243340	0	56157271	09A_0_14579	56157271	0
52456370	04B_0_14068	52456370	0	55243592	005_2_13039	55243592	0	56157274	09A_0_14579	56157274	0
	04B_1_14105	52456370	0	55248041	08A_0_14359	55248041	0	56157282	09A_0_14579	56157282	0
52456389	04B_0_14068	52456389	0		08A_1_14405	55248041	0	56157283	09A_0_14579	56157283	0
	04B_1_14105	52456389	0	55248283	08A_0_14359	55248283	0	56157323	09A_0_14579	56157323	0
52456390	04B_0_14068	52456390	0		08A_1_14405	55248283	0	56157332	08A_0_14359	56157332	0
	04B_1_14105	52456390	0	55248379	09A_0_14579	55248379	0		08A_1_14405	56157332	0
53143128	03A_1_13913	53143128	0	55251686	07A_0_14343	55251686	0	56157341	09A_0_14579	56157341	0
53143712	011_3_13744	53143712	0	55251688	07A_0_14343	55251688	0	56343058	005_2_13039	56343058	0
53143879	03A_1_13913	53143879	0	55257313	09A_0_14579	55257313	0	56347484	002_0_12722	56347484	0
53147482	002_0_12722	53147482	0	55257321	09A_0_14579	55257321	0		002_1_12741	56347484	0
	002_1_12741	53147482	0	56142314	005_2_13039	56142314	0		002_3_12779	56347484	0
53152401	03A_2_13945	53152401	0	56143059	005_2_13039	56143059	0	56349782	002_0_12722	56349782	0
53152408	03A_2_13945	53152408	0	56147520	03A_1_13913	56147520	0		002_1_12741	56349782	0
53152409	03A_2_13945	53152409	0	56147655	08A_0_14359	56147655	0		002_3_12779	56349782	0
53152410	03A_2_13945	53152410	0		08A_1_14405	56147655	0	56351685	07A_0_14343	56351685	0



SPARE PARTS INSTANCE INDEX

Code	Parts Table	Pos.	Q.ty	Code	Parts Table	Pos.	Q.ty	Code	Parts Table	Pos.	Q.ty
56356165	002_3_12779	56356165	0	58043086	04B_0_14068	58043086	0	58052018	012_0_13785	58052018	0
56356251	002_2_12761	56356251	0		04B_1_14105	58043086	0		012_1_13807	58052018	0
	002_3_12779	56356251	0	58043117	03A_1_13913	58043117	0		012_2_13824	58052018	0
56356328	04B_0_14068	56356328	0		03A_2_13945	58043117	0	58052019	012_0_13785	58052019	0
	04B_1_14105	56356328	0	58046901	012_0_13785	58046901	0		012_1_13807	58052019	0
56356329	04B_0_14068	56356329	0		013_0_13845	58046901	0		012_2_13824	58052019	0
	04B_1_14105	56356329	0	58046902	012_0_13785	58046902	0	58052020	012_0_13785	58052020	0
56356330	04B_0_14068	56356330	0		013_0_13845	58046902	0		012_1_13807	58052020	0
	04B_1_14105	56356330	0	58046903	012_0_13785	58046903	0		012_2_13824	58052020	0
56356331	04B_0_14068	56356331	0		013_0_13845	58046903	0	58052021	012_0_13785	58052021	0
	04B_1_14105	56356331	0	58046909	012_0_13785	58046909	0		012_1_13807	58052021	0
56356348	04B_1_14105	56356348	0		013_0_13845	58046909	0		012_2_13824	58052021	0
56359553	011_3_13744	56359553	0	58046910	012_0_13785	58046910	0	58052022	012_0_13785	58052022	0
56359554	011_3_13744	56359554	0		013_0_13845	58046910	0		012_1_13807	58052022	0
56456347	04B_0_14068	56456347	0	58046912	012_0_13785	58046912	0		012_2_13824	58052022	0
	04B_1_14105	56456347	0		013_0_13845	58046912	0	58052023	012_0_13785	58052023	0
56456351	04B_0_14068	56456351	0		013_1_13860	58046912	0		012_1_13807	58052023	0
	04B_1_14105	56456351	0	58046913	012_0_13785	58046913	0		012_2_13824	58052023	0
56456475	04B_0_14068	56456475	0		013_0_13845	58046913	0	58052024	012_0_13785	58052024	0
	04B_1_14105	56456475	0		013_1_13860	58046913	0		012_1_13807	58052024	0
58002429	08A_0_14359	58002429	0	58047568	08A_0_14359	58047568	0		012_2_13824	58052024	0
	08A_1_14405	58002429	0	58047629	08A_0_14359	58047629	0	58052029	012_1_13807	58052029	0
58002538	08A_0_14359	58002538	0		08A_1_14405	58047629	0		012_2_13824	58052029	0
	08A_1_14405	58002538	0	58047712	08A_0_14359	58047712	0	58052033	012_0_13785	58052033	0
58020258	09A_0_14579	58020258	0		08A_1_14405	58047712	0		012_1_13807	58052033	0
58042167	08A_0_14359	58042167	0	58048000	08A_0_14359	58048000	0		012_2_13824	58052033	0
	08A_1_14405	58042167	0		08A_1_14405	58048000	0	58052034	012_0_13785	58052034	0
58042200	08A_0_14359	58042200	0	58048009	08A_0_14359	58048009	0		012_1_13807	58052034	0
	08A_1_14405	58042200	0		08A_1_14405	58048009	0		012_2_13824	58052034	0
58042202	08A_0_14359	58042202	0	58048012	08A_0_14359	58048012	0	58052144	012_1_13807	58052144	0
	08A_1_14405	58042202	0		08A_1_14405	58048012	0		012_2_13824	58052144	0
58042219	07A_0_14343	58042219	0	58050345	08A_0_14359	58050345	0	58052145	012_1_13807	58052145	0
58043053	03A_1_13913	58043053	0	58051670	08A_0_14359	58051670	0		012_2_13824	58052145	0
	03A_2_13945	58043053	0		08A_1_14405	58051670	0	58052146	012_1_13807	58052146	0



SPARE PARTS INSTANCE INDEX

Code	Parts Table	Pos.	Q.ty	Code	Parts Table	Pos.	Q.ty	Code	Parts Table	Pos.	Q.ty
58052146	012_2_13824	58052146	0	58057712	013_0_13845	58057712	0	59057110	08A_1_14405	59057110	0
58052147	012_1_13807	58052147	0		013_1_13860	58057712	0	59057112	08A_0_14359	59057112	0
	012_2_13824	58052147	0	58057722	012_0_13785	58057722	0		08A_1_14405	59057112	0
58052148	012_1_13807	58052148	0		013_0_13845	58057722	0	59057228	09A_0_14579	59057228	0
	012_2_13824	58052148	0		013_1_13860	58057722	0	59057304	09A_0_14579	59057304	0
58052149	012_1_13807	58052149	0	58057724	012_0_13785	58057724	0	59057319	09A_0_14579	59057319	0
	012_2_13824	58052149	0		013_0_13845	58057724	0	59057325	09A_0_14579	59057325	0
58052150	012_2_13824	58052150	0		013_1_13860	58057724	0	59059551	011_3_13744	59059551	0
58052151	012_2_13824	58052151	0	58057732	013_0_13845	58057732	0	59059561	011_3_13744	59059561	0
58052154	012_2_13824	58052154	0		013_1_13860	58057732	0	59059571	011_3_13744	59059571	0
58052155	012_2_13824	58052155	0	58057767	013_1_13860	58057767	0	59247884	002_0_12722	59247884	0
58052274	011_3_13744	58052274	0	58057768	013_1_13860	58057768	0		002_1_12741	59247884	0
58052325	011_3_13744	58052325	0	58057770	013_1_13860	58057770	0		002_2_12761	59247884	0
58052326	011_3_13744	58052326	0	58057771	013_1_13860	58057771	0		002_3_12779	59247884	0
58052327	011_3_13744	58052327	0	58057772	013_1_13860	58057772	0	59247970	002_0_12722	59247970	0
58056155	08A_1_14405	58056155	0	58147704	08A_1_14405	58147704	0		002_1_12741	59247970	0
58056391	04B_0_14068	58056391	0	58150313	08A_0_14359	58150313	0	59247971	002_0_12722	59247971	0
	04B_1_14105	58056391	0		08A_1_14405	58150313	0		002_1_12741	59247971	0
58056593	08A_1_14405	58056593	0	58156156	08A_1_14405	58156156	0		002_2_12761	59247971	0
58057232	09A_0_14579	58057232	0	59015425	03A_1_13913	59015425	0		002_3_12779	59247971	0
58057266	07A_0_14343	58057266	0		03A_2_13945	59015425	0	59256252	002_2_12761	59256252	0
58057273	09A_0_14579	58057273	0	59043063	005_2_13039	59043063	0	59256257	002_3_12779	59256257	0
58057286	08A_0_14359	58057286	0	59047709	08A_0_14359	59047709	0	59256265	002_3_12779	59256265	0
	08A_1_14405	58057286	0		08A_1_14405	59047709	0	59259555	011_3_13744	59259555	0
58057401	08A_1_14405	58057401	0	59047743	011_3_13744	59047743	0	59259563	011_3_13744	59259563	0
58057676	013_0_13845	58057676	0	59047745	011_3_13744	59047745	0	59259567	011_3_13744	59259567	0
	013_1_13860	58057676	0	59052246	09A_0_14579	59052246	0	59259578	011_3_13744	59259578	0
58057678	012_0_13785	58057678	0	59052247	07A_0_14343	59052247	0	59259580	011_3_13744	59259580	0
	013_0_13845	58057678	0	59056365	04B_0_14068	59056365	0	92243685	011_3_13744	92243685	0
	013_1_13860	58057678	0		04B_1_14105	59056365	0	92457794	011_3_13744	92457794	0
58057698	012_0_13785	58057698	0	59056373	04B_0_14068	59056373	0				
	013_0_13845	58057698	0		04B_1_14105	59056373	0				
	013_1_13860	58057698	0	59056900	09A_0_14579	59056900	0				
58057712	012_0_13785	58057712	0	59057110	08A_0_14359	59057110	0				